

# **Oracle Banking Digital Experience**

**Retail Payments User Manual  
Release 18.1.0.0.0**

**Part No. E92727-01**

**January 2018**

**ORACLE®**

Retail Payments User Manual  
January 2018

Oracle Financial Services Software Limited  
Oracle Park  
Off Western Express Highway  
Goregaon (East)  
Mumbai, Maharashtra 400 063  
India

Worldwide Inquiries:

Phone: +91 22 6718 3000

Fax: +91 22 6718 3001

[www.oracle.com/financialservices/](http://www.oracle.com/financialservices/)

Copyright © 2018, Oracle and/or its affiliates. All rights reserved.

Oracle and Java are registered trademarks of Oracle and/or its affiliates. Other names may be trademarks of their respective owners.

U.S. GOVERNMENT END USERS: Oracle programs, including any operating system, integrated software, any programs installed on the hardware, and/or documentation, delivered to U.S. Government end users are “commercial computer software” pursuant to the applicable Federal Acquisition Regulation and agency-specific supplemental regulations. As such, use, duplication, disclosure, modification, and adaptation of the programs, including any operating system, integrated software, any programs installed on the hardware, and/or documentation, shall be subject to license terms and license restrictions applicable to the programs. No other rights are granted to the U.S. Government.

This software or hardware is developed for general use in a variety of information management applications. It is not developed or intended for use in any inherently dangerous applications, including applications that may create a risk of personal injury. If you use this software or hardware in dangerous applications, then you shall be responsible to take all appropriate failsafe, backup, redundancy, and other measures to ensure its safe use. Oracle Corporation and its affiliates disclaim any liability for any damages caused by use of this software or hardware in dangerous applications.

This software and related documentation are provided under a license agreement containing restrictions on use and disclosure and are protected by intellectual property laws. Except as expressly permitted in your license agreement or allowed by law, you may not use, copy, reproduce, translate, broadcast, modify, license, transmit, distribute, exhibit, perform, publish or display any part, in any form, or by any means. Reverse engineering, disassembly, or decompilation of this software, unless required by law for interoperability, is prohibited.

The information contained herein is subject to change without notice and is not warranted to be error-free. If you find any errors, please report them to us in writing.

This software or hardware and documentation may provide access to or information on content, products and services from third parties. Oracle Corporation and its affiliates are not responsible for and expressly disclaim all warranties of any kind with respect to third-party content, products, and services. Oracle Corporation and its affiliates will not be responsible for any loss, costs, or damages incurred due to your access to or use of third-party content, products, or services.

# Table of Contents

<b>1. Preface.....</b>	<b>5</b>
1.1 Intended Audience .....	5
1.2 Documentation Accessibility .....	5
1.3 Access to Oracle Support .....	5
1.4 Structure.....	5
1.5 Related Information Sources.....	5
<b>2. Transaction Host Matrix.....</b>	<b>6</b>
<b>3. Payments.....</b>	<b>10</b>
3.1 Payments Widgets .....	11
<b>4. Transfer Money.....</b>	<b>14</b>
4.1 Transfer Money – Existing Payee .....	15
4.2 Transfer Money - New Payee .....	23
4.3 Transfer Money – My Accounts .....	24
<b>5. Multiple Transfers.....</b>	<b>27</b>
<b>6. Adhoc Transfer .....</b>	<b>37</b>
6.1 Adhoc Payment - Internal Fund Transfer.....	38
6.2 Adhoc Payment - Domestic Fund Transfer.....	41
6.3 Adhoc Payment - International Fund Transfer .....	44
<b>7. Manage Payees.....</b>	<b>55</b>
7.1 Payee Summary.....	56
7.2 View Payee Details .....	58
7.3 Edit Payee (Account Limits).....	63
7.4 Delete Payee Account/Demand Draft .....	67
7.5 Add New Payee .....	69
<b>8. Add Payee – Bank Account.....</b>	<b>70</b>
8.1 Add Payee – Internal Bank Account .....	72
8.2 Add Payee – Domestic Bank Account .....	73
8.2.1 Domestic Account – India .....	73
8.2.2 Domestic Account – UK .....	76
8.2.3 Domestic Account – SEPA Payment .....	83
8.3 Add Payee – International Bank Account .....	87
<b>9. Add Payee – Demand Draft .....</b>	<b>91</b>

9.1	Add Payee – Domestic Demand Draft .....	93
9.2	Add Payee – International Demand Draft .....	95
<b>10.</b>	<b>Manage Biller .....</b>	<b>99</b>
10.1	Manage Billers – Summary .....	99
10.2	View Biller Details .....	101
10.3	Edit Biller .....	102
10.4	Add Biller .....	103
10.5	Delete Biller .....	105
<b>11.</b>	<b>Issue Demand Draft .....</b>	<b>107</b>
11.1	Demand Draft .....	108
<b>12.</b>	<b>Bill Payment.....</b>	<b>111</b>
12.1	Pay Bills.....	111
<b>13.</b>	<b>Multiple Bill Payments .....</b>	<b>114</b>
<b>14.</b>	<b>Manage Debtors .....</b>	<b>119</b>
14.1	Manage Debtors – View .....	121
14.2	Add Debtor .....	122
14.3	Delete Debtor .....	123
<b>15.</b>	<b>Request Money.....</b>	<b>125</b>
<b>16.</b>	<b>Repeat Transfers .....</b>	<b>128</b>
16.1	View Repeat Transfers.....	129
16.2	Stop Repeat Transfers .....	132
16.3	Set Repeat Transfers .....	134
<b>17.</b>	<b>Favorites .....</b>	<b>142</b>
17.1	Favorites – Summary .....	143
17.2	Remove Favorites .....	144
<b>18.</b>	<b>Upcoming Payments Inquiry.....</b>	<b>147</b>
18.1	Upcoming Payment – Summary .....	148
18.2	Upcoming Payments – View & Cancel .....	149
<b>19.</b>	<b>Common Functions .....</b>	<b>151</b>

# 1. Preface

## 1.1 Intended Audience

This document is intended for the following audience:

- Customers
- Partners

## 1.2 Documentation Accessibility

For information about Oracle's commitment to accessibility, visit the Oracle Accessibility Program website at <http://www.oracle.com/pls/topic/lookup?ctx=acc&id=docacc>.

## 1.3 Access to Oracle Support

Oracle customers have access to electronic support through My Oracle Support. For information, visit

<http://www.oracle.com/pls/topic/lookup?ctx=acc&id=info> or visit

<http://www.oracle.com/pls/topic/lookup?ctx=acc&id=trs> if you are hearing impaired.

## 1.4 Structure

This manual is organized into the following categories:

*Preface* gives information on the intended audience. It also describes the overall structure of the User Manual.

*Introduction* provides brief information on the overall functionality covered in the User Manual.

The subsequent chapters provide information on transactions covered in the User Manual.

Each transaction is explained in the following manner:

- Introduction to the transaction
- Screenshots of the transaction
- The images of screens used in this user manual are for illustrative purpose only, to provide improved understanding of the functionality; actual screens that appear in the application may vary based on selected browser, theme, and mobile devices.
- Procedure containing steps to complete the transaction- The mandatory and conditional fields of the transaction are explained in the procedure.

If a transaction contains multiple procedures, each procedure is explained. If some functionality is present in many transactions, this functionality is explained separately.

## 1.5 Related Information Sources

For more information on Oracle Banking Digital Experience Release 18.1.0.0.0, refer to the following documents:

- Oracle Banking Digital Experience Licensing Guide
- Oracle Banking Digital Experience Installation Manuals

## 2. Transaction Host Matrix

### Legends

<b>NH</b>	No Host Interface Required.
✓	Pre integrated Host interface available.
×	Pre integrated Host interface not available.

Sr No	Transaction / Function Name	FCR 11.7.0.0. 0	UBS 12.3.0.0. 0	UBS 12.4.0.0. 0	UBS 14.0.0.0. 0 (FT/PC)	UBS 14.0.0.0. 0 (OBPM)
1	Payments Widgets	✓	✓	✓	✓	✓
2	Transfer Money	□	□	□	□	□
	Own Accounts	✓	✓	✓	✓	✓
	Internal Account	✓	✓	✓	✓	✓
	India Domestic - NEFT	✓	✓	✓	✓	×
	India Domestic - RTGS	✓	✓	✓	✓	✓
	India Domestic - IMPS	✓	×	×	×	×
	SEPA - Credit Transfer	×	✓	✓	✓	✓
	SEPA - Card Transfer	×	×	×	×	×
	UK - Urgent	×	×	×	×	×
	UK - Non urgent	×	×	×	×	×
	UK - Faster	×	×	×	×	×
	International Transfer	×	✓	✓	✓	✓
3	Adhoc Transfer	□	□	□	□	□
	Internal Account	✓	✓	✓	✓	✓
	India Domestic - NEFT	✓	✓	✓	✓	×
	India Domestic - RTGS	✓	✓	✓	✓	✓
	India Domestic - IMPS	✓	×	×	×	×
	International Transfer	×	✓	✓	✓	✓

Sr No	Transaction / Function Name	FCR 11.7.0.0. 0	UBS 12.3.0.0. 0	UBS 12.4.0.0. 0	UBS 14.0.0.0. 0 (FT/PC)	UBS 14.0.0.0. 0 (OBPM)
4	Multiple Transfers	☐	☐	☐	☐	☐
	Internal Account	✓	✓	✓	✓	✓
	India Domestic - NEFT	✓	✓	✓	✓	✗
	India Domestic - RTGS	✓	✓	✓	✓	✓
	India Domestic - IMPS	✓	✗	✗	✗	✗
	SEPA - Credit Transfer	✗	✓	✓	✓	✓
	SEPA - Card Transfer	✗	✗	✗	✗	✗
	UK - Urgent payment	✗	✗	✗	✗	✗
	UK - Non urgent payment	✗	✗	✗	✗	✗
	UK - Faster payment	✗	✗	✗	✗	✗
	International Transfer	✗	✓	✓	✓	✓
5	Manage Payees	☐	☐	☐	☐	☐
	Internal*	✓	✓	✓	✓	✓
	India Domestic - NEFT*	✓	✓	✓	✓	✗
	India Domestic - RTGS*	✓	✓	✓	✓	✓
	India Domestic - IMPS*	✓	✗	✗	✗	✗
	International Transfer*	✗	✓	✓	✓	✓
	SEPA - Credit Transfer*	✗	✓	✓	✓	✓
	SEPA - Card Transfer*	✗	✗	✗	✗	✗
	UK - Urgent Payment*	✗	✗	✗	✗	✗
	UK - Non urgent Payment*	✗	✗	✗	✗	✗
	UK - Faster Payment*	✗	✗	✗	✗	✗
	Domestic Draft*	✓	✓	✓	✓	✓
	International Draft*	✗	✓	✓	✓	✓
6	Manage Biller*	✓	✓	✓	✓	✗

Sr No	Transaction / Function Name	FCR 11.7.0.0. 0	UBS 12.3.0.0. 0	UBS 12.4.0.0. 0	UBS 14.0.0.0. 0 (FT/PC)	UBS 14.0.0.0. 0 (OBPM)
7	Demand Draft	☐	☐	☐	☐	☐
	Domestic - Pay Now	✓	✓	✓	✓	✓
	Domestic - Pay Later	✓	✗	✗	✗	✓
	International - Pay Now	✗	✓	✓	✓	✓
	International - Pay Later	✗	✓	✓	✓	✓
8	Repeat Transfers	☐	☐	☐	☐	☐
	Own Accounts	✓	✓	✓	✓	✗
	Internal Accounts	✓	✓	✓	✓	✗
	India Domestic - NEFT	✓	✓	✓	✓	✗
	India Domestic - RTGS	✗	✓	✓	✓	✗
	India Domestic - IMPS	✗	✗	✗	✗	✗
9	Bill Payments	✓	✓	✓	✓	✗
10	Multiple Bill Payments	✓	✓	✓	✓	✗
11	Manage Debtors	✗	✓	✓	✓	✓
12	Request Money	✗	✓	✓	✓	✓
13	Upcoming Payment Inquiry	☐	☐	☐	☐	☐
	Own Account - Repeat Payment	✓	✓	✓	✓	✓
	Own Account - Pay Later	✓	✓	✓	✓	✓
	Internal Transfer - Repeat Payment	✓	✓	✓	✓	✓
	Internal Transfer - Pay Later	✓	✓	✓	✓	✓
	India Domestic - NEFT - Repeat Payment	✓	✓	✓	✓	✗
	India Domestic - NEFT - Pay Later	✓	✓	✓	✓	✗



Sr No	Transaction / Function Name	FCR 11.7.0.0.0	UBS 12.3.0.0.0	UBS 12.4.0.0.0	UBS 14.0.0.0.0 (FT/PC)	UBS 14.0.0.0.0 (OBPM)
	India Domestic - RTGS - Repeat Payment	x	✓	✓	✓	x
	India Domestic - RTGS - Pay Later	✓	✓	✓	✓	✓
	India Domestic - IMPS - Repeat Payment	x	x	x	x	x
	India Domestic - IMPS - Pay Later	✓	x	x	x	x
	International Transfer - Pay Later	x	✓	✓	✓	✓
	SEPA Credit Transfer - Pay Later	x	✓	✓	✓	✓
	Domestic Draft - Pay Later	✓	x	x	x	✓
	International Draft - Pay Later	x	✓	✓	✓	✓
14	Upcoming Payment Cancellation	✓	✓	✓	✓	✓
15	Favorites	NH	NH	NH	NH	NH
* There is an integration required with the host system to validate some information captured as part of payee details whereas there is no storage of payees in the host system.						

### **3. Payments**

Payments, specifically Retail Payments, are fund transfers made between individuals and are, in most instances, of a low value and are generally not time-sensitive in nature.

Retail payments are mostly made by consumers to retailers or to utility providers and involve the transfer of money from the consumer's account to that of the service provider.

The digital banking application simplifies the user's requirement of transferring funds from one bank account to others. By using the payments module of the digital banking application, users can transfer funds between accounts (including their own as well as to other accounts held within the same bank or outside the bank either domestically or internationally) at their convenience in a simplified manner.

The following sections in this document detail all the features offered to users through the payments module of the digital banking application.

### 3.1 Payments Widgets

In addition to a host of other banking features and information, the retail user dashboard also contains two widgets related to payments which enable users to easily access payment transactions and also to gain a quick view of scheduled upcoming payments.

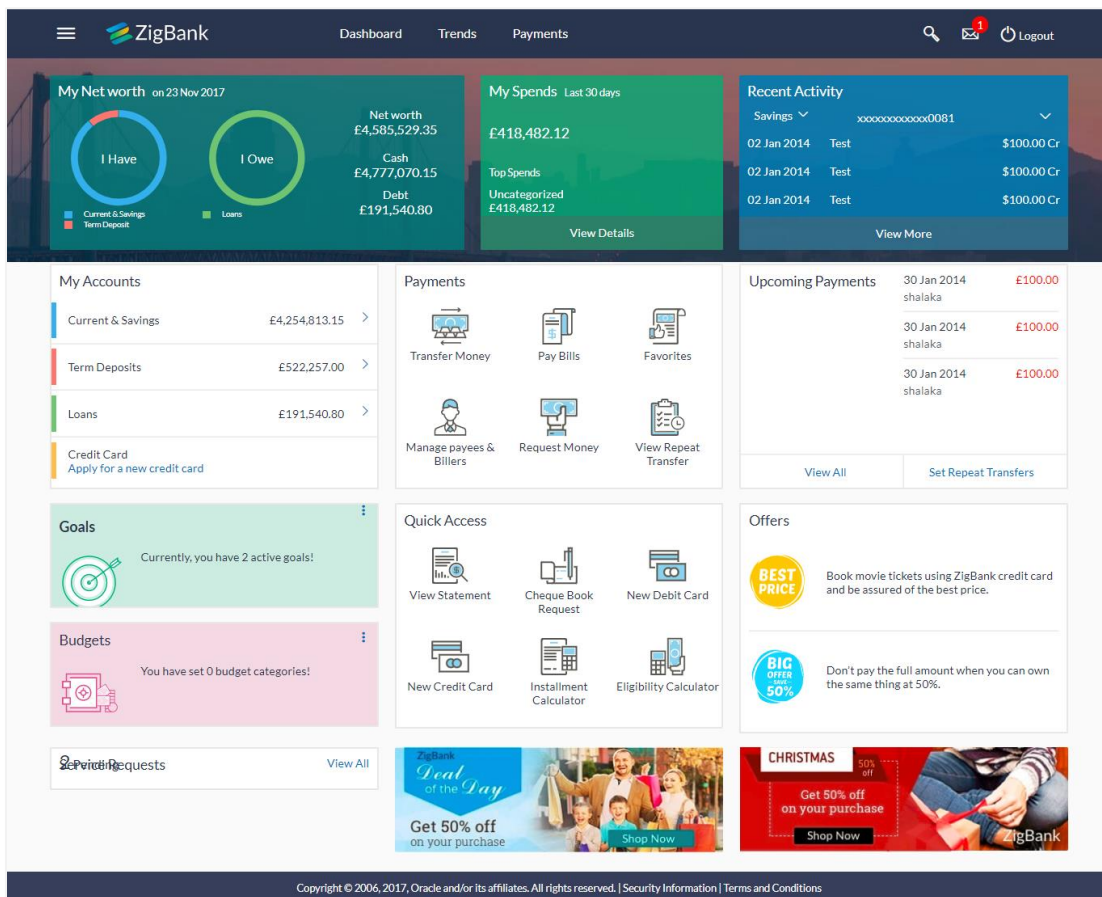

## **Payments Widget Overview**

The payments widget enables the user to gain easy access to the following transactions and features:

### **Transfer Money**

This feature enables the user to transfer money to registered payees.

### **Pay Bills**

This feature enables users to pay utility bills towards billers that are previously registered.

### **Favorites**

By selecting this option, users can access the transactions, both bill payments and money transfers that they have set as favorite. Users can subsequently initiate further transactions using these favorite transactions as templates.

### **Manage Payees & Billers**

This feature enables users to manage payees and billers. From the Manage Payees & Billers screen, the user can add new payees or billers and can also view and edit or delete existing registered payees and billers.

### **Request Money**

The Request Money feature enables users to initiate SEPA direct debit requests.

### **View Repeat Transfers**

This feature enables users to view previously initiated repeat transfers. Subsequently, users can also initiate repeat transfers by selecting the Set Repeat Transfers option available on the View Repeat Transfers screen.

---

## Upcoming Payments Widget Overview

### Upcoming Payments

This widget lists down all the future dated payment instructions set up by the user. By default, only four future dated payments that are due within 30 days are displayed on the widget. The user is provided with the option to view all upcoming payments by selecting the View All link.

Each payment record displays the date on which the payment is due, the amount of payment and the name/nickname of the payee towards whom the payment is to be made.

### Set Repeat Transfers

The Upcoming Payments widget also contains a link by which the user is able to setup new repeat transfers and also view repeat transfers that have already been initiated.

If the user has no upcoming payments, this widget will only contain the 'Set Repeat Transfers' link.

---

[Home](#)

## 4. Transfer Money

The Transfer Money feature enables the user to initiate online payments from his bank account to any other bank account. Through this feature, the user is provided with the option to either transfer funds within his own accounts held in the same bank by selecting the 'My Accounts' option or to transfer funds to other accounts (held within the same bank or in other banks within the same country or even to accounts held beyond geographical boundaries) by selecting the 'Existing Payee' option. The 'New Payee' option enables the user to initiate peer to peer payments towards email or mobile contacts or even towards facebook contacts. The user can also opt to register payees towards whom he intends to initiate payments in the future by selecting the option 'Bank Account' under the 'New Payee' option.

On selecting the option, 'Existing Payee', the user has to simply select a payee and subsequently select the specific account of the payee towards which the transfer is to take place. The user is not required to explicitly select the transfer type (internal, domestic or international) since this categorization is undertaken at the time of payee creation when defining the payees bank account details.

Transfer money also allows initiating Peer to Peer transfer via New Payee option (email/mobile, bank account).

### Prerequisites:

- Transaction and account access is provided to retail user
- Transaction working window is maintained
- Payees are registered for the purpose of transferring funds via the 'Existing Payee' option
- The retail user has a valid active facebook accounts for the purpose of transferring funds via Facebook available as a sub option under the 'New Payee' option.
- Purpose of Payments are maintained
- Transaction limits are assigned to user to perform the transaction
- Payee limits, cooling period along with transaction limits are maintained

### Features supported in the application

The 'Transfer Money' feature enables users to make payments towards:

- Existing Payees – Internal, Domestic and International transfers are supported and are triggered based on the payee and specific payee account selection.
- To My Account – Users are able to transfer funds within their own accounts held in the bank.
- To New Payee – By selecting this option, users can initiate fund transfers towards email, mobile and facebook contacts. Alternately, if the intended recipient of the funds is not yet registered as a payee, the user can also select the option 'Bank Account' in order to be navigated to the screen from which he can register an intended recipient as a payee.

## Workflow

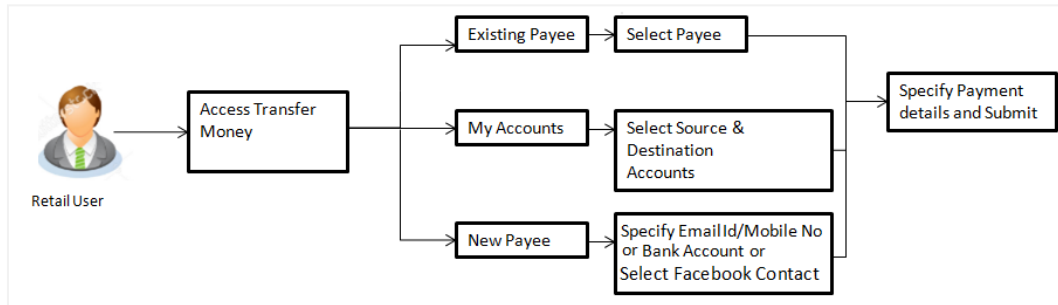

### How to reach here:

*Dashboard > Payments Widget > Transfer Money*

OR

*Dashboard > Toggle Menu > Payments > Transfer Money*

OR

*Dashboard > Payments Menu > Transfer Money*

## 4.1 Transfer Money – Existing Payee

The existing payee option of the 'Transfer Money' feature enables the user to initiate payments towards existing registered payees. All account payees created by the logged in user are listed for selection. On selecting a payee, the user must select the specific account of the payee towards which the transfer is to be made. Once the payee's account has been selected, the details are auto populated on transaction screen. The user is then required to fill in payment details to initiate the funds transfer. Payment details will vary based on the transfer type associated with the payee's account. The user can also view the payee and transaction limits by selecting the 'View Limits' link provided on the screen.

### How to reach here:

*Dashboard > Payments Widget > Transfer Money > Existing Payee*

OR

*Dashboard > Toggle Menu > Payments > Transfer Money > Existing Payee*

OR

*Dashboard > Payments Menu > Transfer Money > Existing Payee*

### To transfer money to existing payee:

1. In the **Transfer Type** field, select the **Existing Payee** option. The fields by which to initiate a fund transfer to an existing payee appear.

## Transfer Money – Existing Payee

☰ ZigBank
Dashboard Trends Payments
🔍
📧 9
🔌 Logout

Transfer Money
Favorites
Transfer Money
Adhoc Transfer
Multiple Transfers
Issue Demand Drafts
Upcoming Payments
Pay Bills
Multipl >

Transfer Type
 Existing Payee
 New Payee
 My Accounts

Payee  
Jack 🔄

Jack Williams - Jack

Account Number	Account Type	Account Name
AT30025430013	International	Ash Mellor

Payee Address  
Example Co., Avenida Vitacura 2939, CA, US

Bank Details  
CITIGB2LXXX, CITIBANK INTERNATIONAL LONDON, CITIGB2LXXX, GB

Transfer From  
xxxxxxxxxxxx0040 ▼

Balance: £2,995,233.89

Amount  
EUR ▼ €1,000.00

[View Limits](#)

Transfer When  
 Now  Later

Correspondence Charges  
SHARED ▼

Transfer via Intermediary Bank  
 Yes  No

Pay Via  
 SWIFT Code  NCC  Bank Details

SWIFT Code  
AKBKGB99  
ANTHOS ASSET MANAGEMENT B.V.  
111, JACHTHAVENWEG  
AMSTERDAM  
GB

Reset

Payment Details  
Against POE89323

[Add Payment Details](#)

Note (Optional)

---

80 Characters Left

Transfer
 Cancel

**Transferring money is convenient, fast and secure via the ZigBank Transfer Money service.**

Using this service you can transfer money from your ZigBank savings or current account to any of your registered payees across the globe. ZigBank also enables you to transfer money to your friends' Email, Mobile Number or Facebook accounts in case you don't have their account information handy.

**Want to make an account transfer now but have not yet registered the payee?** No problem! Use the Zigbank Adhoc Transfer service to transfer money to any bank account by simply specifying the account number and supporting bank and branch information. This service also allows you to register the payee for future use, once you have made the transfer.

**Did you know?** You can also initiate multiple transfers towards numerous payees at once. All you have to do is select the [Multiple Transfers](#) option to get started.

[Back to Dashboard](#)

Copyright © 2006, 2017, Oracle and/or its affiliates. All rights reserved. | [Security Information](#) | [Terms and Conditions](#)



## Field Description

Field Name	Description
<b>Transfer Type</b>	<p>Select the type of transfer that you wish to initiate.</p> <p>The options are:</p> <ul style="list-style-type: none"> <li>Existing payee</li> <li>New payee</li> <li>My Accounts (User's own accounts)</li> </ul>
<b>Existing Payee</b>	
<p>The following fields appear if the <b>Existing Payee</b> option is selected in <b>Transfer Type</b> field.</p>	
<b>Payee</b>	<p>Select the payee towards whom you wish to make a funds transfer and subsequently select the specific account of the payee in which the funds are to be transferred.</p>
<p>The following details of the selected payee appear once you have selected the payee and payee account number from the <b>Payee</b> field.</p>	
<b>Account Number</b>	<p>On selecting the payee, the account number associated with the payee appears.</p>
<b>Account Type</b>	<p>Type of account or transfer type associated with the payee appears, once a payee is selected.</p>
<b>Account Name</b>	<p>The name of the payee in the bank account appears.</p>
<b>Payee Address</b>	<p>Address of the payee in the bank account.</p> <p>This field appears for <b>International</b> type of payee.</p>
<b>Bank Details</b>	<p>The details of the bank i.e. the name and address of the bank's branch in which the payee's account is held appears.</p>
<b>Transfer From</b>	<p>Select the source account from which the funds are to be transferred.</p>
<b>Balance</b>	<p>On selecting a source account, the net balance of the account appears below the <b>Transfer From</b> field.</p>
<b>Currency</b>	<p>Select the currency in which the transfer is to take place.</p> <p>Currency is defaulted to destination account currency for Own and Internal Transfer and local currency for Domestic Transfer.</p> <p>For International transfer, the user can select the currency from the list.</p>
<b>Amount</b>	<p>Specify the amount to be transferred.</p>

Field Name	Description
<b>View Limits</b>	Link to view the transaction limits applicable to the user.
<b>Transfer When</b>	<p>The facility to specify when the funds are to be transferred.</p> <p>The options are:</p> <ul style="list-style-type: none"> <li>• Now: transfer funds on the same day</li> <li>• Later: transfer funds on a future date</li> </ul>
<b>Transfer Date</b>	<p>Date of transfer.</p> <p>This field appears if you select option <b>Later</b> is selected from the <b>Transfer When</b> list.</p>
<b>Originators Identification Number</b>	<p>The Originator's Identification Number is the unique number given to participants who are authorized to use the Direct Debit Scheme.</p> <p>This field appears if you select <b>Domestic</b> type of payee from the Payee list.</p>
<b>OIN Description</b>	<p>A brief description of the OIN.</p> <p>This field appears if you select <b>Domestic</b> type of payee from the Payee list.</p>
<b>Purpose</b>	<p>Select purpose of the transfer.</p> <p>If purpose of transfer is selected as 'Other, an additional field is displayed in which the user can specify a purpose which is not defined in the list.</p> <p>This field appears when the transfer being initiated is an internal or domestic transfer.</p>
<b>Correspondence Charges</b>	<p>The facility to select the party by whom transfer charges are to be borne.</p> <p>The options are:</p> <ul style="list-style-type: none"> <li>• Payee: transfer charges are to be borne by the beneficiary</li> <li>• Payer: transfer charges are to be borne by the ordering customer</li> <li>• Shared: transfer charges are to be borne by both the payee and payer</li> </ul> <p>This field appears if the transfer being initiated is an international transfer.</p>
<b>Transfer via Intermediary Bank</b>	<p>Specify whether the fund transfer is to be done through intermediary bank.</p> <p>This field appears only for <b>International</b> Payee.</p>

Field Name	Description
<b>Pay Via</b>	<p>Network for payment.</p> <p>The options are:</p> <ul style="list-style-type: none"> <li>• Swift Code</li> <li>• NCC (National Clearing code)</li> <li>• Bank Details</li> </ul> <p>This field appears if you select <b>Yes</b> option from <b>Transfer via Intermediary Bank</b> field.</p>
<b>SWIFT / National clearing code value</b>	SWIFT code /National Clearing code value.
<b>SWIFT code Look up</b>	
Below fields appears if the <b>SWIFT Code</b> option is selected in <b>Pay Via</b> field.	
<b>Lookup Swift Code</b>	Link to search the SWIFT code.
<b>SWIFT Code</b>	SWIFT code value.
<b>Bank Name</b>	Bank name to search the SWIFT code.
<b>Country</b>	Country name to search the SWIFT code.
<b>City</b>	City name to search the SWIFT code.
<b>SWIFT code Lookup - Search Result</b>	
<b>Bank Name</b>	Name of the bank.
<b>Address</b>	Displays complete address of the bank.
<b>SWIFT Code</b>	SWIFT code /National Clearing code value.
<b>National clearing code Look up</b>	
Below fields appears if the <b>National clearing code</b> option is selected in <b>Pay Via</b> field.	
<b>Lookup National clearing code</b>	Link to search the National clearing code.
<b>NCC Type</b>	NCC type of the bank branch.
<b>NCC Code</b>	NCC code of the bank branch.
<b>Bank Name</b>	Name of the bank.
<b>City</b>	City to which the bank belongs.

Field Name	Description
<b>NCC Lookup - Search Result</b>	
<b>Bank Name</b>	Name of the bank.
<b>Branch</b>	Bank branch name.
<b>Address</b>	Address of the bank.
<b>NCC Code</b>	NCC code of the bank branch.
Below fields appears if the Bank Details option is selected in Pay Via field.	
<b>Bank Name</b>	Name of the bank.
<b>Bank address</b>	Complete address of the bank.
<b>Country</b>	Country of the bank.
<b>City</b>	City to which the bank belongs.
<b>Payment Details</b>	Specify payment details. This field appears if the transfer type being initiated is an international transfer.
<b>Add Payment Details</b>	The link to add more details of the transfer. This field appears only for <b>International</b> Payee.
<b>Note</b>	Narrative for the transaction.

2. From the **Payee** list, select the preferred payee, and subsequently select the specific account of the payee towards which the transfer is to be made.  
The payee details of the selected payee appear.  
OR  
Click  if you want to select a different payee.
3. From the **Transfer From** account list, select the account from which transfer needs to be made.
4. If the transfer being initiated is towards an International account, select the appropriate currency from the **Currency** list.
5. In the **Amount** field, enter the transfer amount.
6. In the **Transfer When** field, select the option to indicate when the transfer is to take place.
  - a. If you select the option **Now**, the transfer will be made on the same day.  
OR
  - b. If you select the option **Later**, select the date on which you want the transfer to be initiated from the **Transfer Date** field.
7. If the transfer type is **Internal**, select the appropriate purpose of transfer from the **Purpose** list.

OR

If the transfer type is **Domestic**:

- a. In the **Originators Identification Number** field, enter the identification number of the originator.
- b. In the **OIN Description** field, enter the description for the OIN.
- c. From the **Purpose** list, select the appropriate purpose of transfer.

OR

If the transfer type is **International**,

- a. From the Correspondence Charges list, select the appropriate option.
  - b. In the **Transfer via Intermediary Bank** field, select the appropriate option.
  - c. If you have selected **Yes** option in the **Transfer via Intermediary Bank** field, select the appropriate network for payment in the **Pay Via** field.
    1. If you select **Swift** option:
      - i. In the **SWIFT code** field, enter the SWIFT code or search and select it from the lookup.
      - ii. Click **Verify** to fetch bank details based on Bank Code (BIC).
    2. If you select **National Clearing code** option:
      - i. In the **National Clearing code** field, enter the National Clearing code or search and select it from the lookup.
      - ii. Click **Verify** to fetch bank details based on Bank Code (BIC).
    3. If you select **Bank details** option:
      - i. In the **Bank Name** field, enter the bank name.
      - ii. In the **Bank Address** field, enter the complete address of the bank.
      - iii. From the **Country** list, select the country of the bank.
      - iv. From the **City** list, select the city to which the bank belongs.
  - d. In the **Payment Details** field, enter the details about the fund transfer.
8. Click **Transfer** to initiate the payment.
- OR
- Click **Cancel** to cancel the operation and navigate back to 'Dashboard'.
- OR
- Click the **Back to Dashboard** link, to navigate to the dashboard.

9. The **Transfer Money - Review** screen appears. Verify the details, and click **Confirm**.

OR

Click **Back** to navigate back to the previous screen.

OR

Click **Cancel** to cancel the operation and navigate back to 'Dashboard'.

10. The **Verification** screen appears if the transaction is configured Two Factor Authentication.

11. The success message appears, along with the host reference number UTER (for International Payee) and transaction details.

Click **Go to Dashboard**, to navigate to the dashboard.

OR

Click **More Payment Options** to access other payment options.

OR

Click **Add Favorite** to mark the transaction as favorite.  
OR  
Click **Set Repeat Transfer** to initiate standing instructions.

---

**Note:** 'Set Repeat Transfer' link appears only in the case of Domestic and Internal Transfers.

---

## 4.2 Transfer Money - New Payee

By selecting the 'New Payee' option, the user is provided with three choices by which to initiate a fund transfer. They are as follows:

### **Email/Mobile**

The Email/Mobile option enables the user to initiate a funds transfer towards an email or mobile contact. The user has to simply specify the email address or the mobile number of the intended payee and specify other transfer related details such as the transfer amount and source account. Once the transfer is initiated, the funds are transferred to the account number associated with that email address or mobile number.

### **Bank Account**

The user can select this option if he wishes to initiate a transfer towards a beneficiary who is not yet registered as a payee. On selecting this option, the user will be directed to a screen from which he can select the option to navigate to the screen on which he can register a payee.

### **Facebook**

By selecting this option, the user is able to transfer funds to a facebook contact. Funds can be transferred towards only those facebook contacts who have registered themselves for this facility with the bank via facebook.

Using this option you can transfer funds from your account to payee account within the bank, within the country or outside the country by specifying email or mobile number or to your facebook contacts having zigbank bank account. The funds transfer is done through peer to peer if payee is not added. You can also maintain payee contact details like email address /mobile number.

For details on the **New Payee** option under Transfer Money, refer the User Manual **Oracle Banking Digital Experience Retail Peer to Peer Payment**.

## 4.3 Transfer Money – My Accounts

By selecting the 'My Accounts' option as transfer type, the user is able to initiate funds towards his own accounts held with the bank.

### To transfer money to own account:

1. In the **Transfer Type** field, select the **My Accounts** option. The fields by which to initiate an own account transfer appear.

### Transfer Money - My Accounts

The screenshot shows the ZigBank 'Transfer Money' interface. The 'Transfer Type' section has three radio buttons: 'Existing Payee', 'New Payee', and 'My Accounts', with 'My Accounts' selected. Below this, the 'Transfer To' and 'Transfer From' fields both show 'xxxxxxxxxxxx0309' with a balance of '£43,611.00'. The 'Amount' is set to 'GBP' and '£1,000.00'. The 'Transfer When' section has 'Now' and 'Later' options, with 'Later' selected. The 'Transfer Date' is '30 Sep 2019'. A note is present: 'Transfer against the payment of invoice IN34345'. At the bottom, there are 'Transfer' and 'Cancel' buttons. A right-hand panel contains a message about the convenience and security of the service, along with instructions for unregistered payees and information about multiple transfers.

### Field Description

#### Field Name Description

<b>Transfer Type</b>	Select the type of transfer that you wish to initiate The options are: <ul style="list-style-type: none"> <li>• Existing payee</li> <li>• New payee</li> <li>• My Accounts (User's own accounts)</li> </ul>
----------------------	--

### My Accounts



Field Name	Description
------------	-------------

<b>Transfer To</b>	Select the account number towards which you want to transfer funds.
<b>Balance</b>	The net balance of the selected account is displayed once an account is selected in the Account Number field.
<b>Transfer From</b>	Select the source account from which the funds are to be transferred.
<b>Balance</b>	On selecting a source account, the net balance of the account appears below the <b>Transfer From</b> field.
<b>Currency</b>	Select the currency in which the transfer is to take place. Currency is defaulted to destination account currency for Own and Internal Transfer and local currency for Domestic Transfer. For International transfer, the user can select the currency from the list.
<b>Amount</b>	Specify the amount to be transferred.
<b>View Limits</b>	Link to view the transaction limits applicable to the user.
<b>Transfer When</b>	The facility to specify when the funds are to be transferred. The options are: <ul style="list-style-type: none"> <li>• Now: transfer funds on the same day</li> <li>• Later: transfer funds on a future date</li> </ul>
<b>Transfer Date</b>	Date of transfer. This field appears if you select option <b>Later</b> is selected from the <b>Transfer When</b> list.
<b>Note</b>	Narrative for the transaction.

2. From the **Transfer To** list, select the account to which the funds need to be transferred.
3. From the **Transfer From** account list; select the account from which transfer needs to be made.
4. In the **Amount** field, enter the transfer amount.
5. In the **Transfer When** field, select the option to indicate when the transfer is to take place.
  - a. If you select the option **Now**, the transfer will be made on the same day.  
OR
  - b. If you select the option **Later**, select the date on which you want the transfer to be initiated from the **Transfer Date** field.
6. Click **Transfer** to initiate the funds transfer.  
OR

- Click **Cancel** to cancel the operation and navigate back to 'Dashboard'.  
OR  
Click the **Back to Dashboard** link, to navigate to the dashboard.
7. The **Transfer Money - Review** screen appears. Verify the details, and click **Confirm**.  
OR  
Click **Back** to navigate back to the previous screen.  
OR  
Click **Cancel** to cancel the operation and navigate back to 'Dashboard'.
8. The **Verification** screen appears if transaction is configured for Two Factor Authentication.
9. The success message appears along with the host reference number and transaction details.  
Click **Go to Dashboard**, to navigate to the dashboard.  
OR  
Click **More Payment Options** to access other payment options.  
OR  
Click **Add Favorite** to mark the transaction as favorite.  
OR  
Click **Set Repeat Transfer** to initiate standing instructions.

## **FAQs**

1. **Can I use the Transfer Money transaction to transfer the funds towards the repayment of a loan that I hold in same bank?**
- No, fund transfers can be made only to current or savings account through the transfer money transaction.
2. **Can I set a future date for a fund transfer?**
- You can set a future date for a payment using the Pay Later option.
3. **What happens if I have set up a future dated transfer, but don't have enough funds in my account on the transaction date for the transfer?**
- Balance check will not be performed at the time of transaction initiation with future date. The transaction will get declined in case of insufficient funds in the account on the given transaction date
4. **What happens if the transaction amount is less than set Transaction Limit?**
- If the transaction amount is less than the minimum limit or more than the maximum transaction limit set by the Bank, the user will not be able to initiate the transfer.
5. **Can I make a payment to an account which is currently not registered as my payee?**
- If you want to make a payments towards a beneficiary who is not yet registered you can select the option, 'Bank Account' under the 'New Payee' option to be navigated to the screen on which you can register the intended beneficiary as a payee. You can then initiate transfers towards this payee via the 'Existing Payee' option. Alternately, you can transfer funds towards accounts that you have not registered through the 'Adhoc Transfer' transaction.

[Home](#)

## 5. Multiple Transfers

The Multiple Transfers feature enables users to initiate transfers towards a group of people as part of a single transaction. Through this feature, users can initiate transfers towards registered payees of different transfer types i.e. internal, domestic and international transfers, with different transfer dates, all at once from a single screen.

### Prerequisites:

- Transaction and account access is provided to the retail user
- Transaction working window is maintained for the underlying transfer types
- Registered payees are maintained
- Purpose of Payments are maintained
- Transaction limits are assigned to the user to perform the transaction
- Payee limits and cooling period limits are maintained

### Workflow

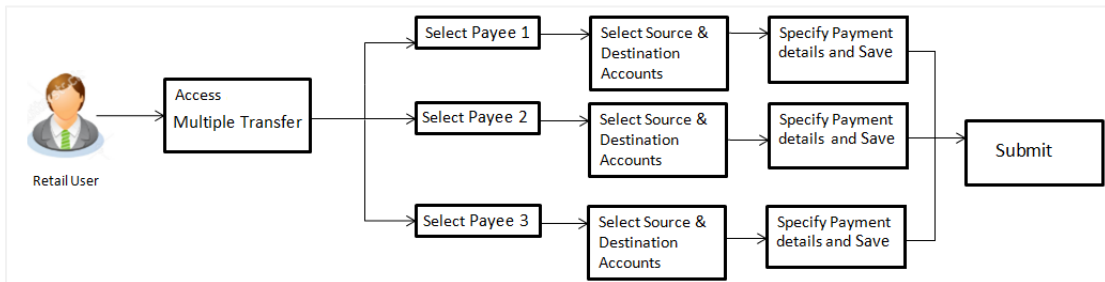

### How to reach here:

*Dashboard > Toggle Menu > Payments > Multiple Transfers*

*OR*

*Dashboard > Payments Menu > Multiple Transfers*

### Multiple Transfers

ZigBank
Dashboard Trends Payments
Logout

---

Multiple Transfers
Favorites
Transfer Money
Adhoc Transfer
Multiple Transfers
Issue Demand Drafts
Upcoming Payments
Pay Bills
Multi >

**Payee 1**

Payee: Jack

Jack-Williams - Jack		
Account Number	Account Type	Account Name
AT90025430013	International	Ash Mellor
Payee Address		
Example Co., Avenida Vitacura 2939, CA, US		
Bank Details		
CITIGB2LXXX,CITIBANK INTERNATIONAL LONDON,CITIGB2LXXX,GB		

Transfer From: xxxxxxxxxxxx0029

Balance: £1,900,351.85

Amount: EUR €1,000.00 [View Limits](#)

Transfer When:  Now  Later

Correspondence Charges: SHARED

Transfer via Intermediary Bank:  Yes  No

Pay Via:  SWIFT Code  NCC  Bank Details

SWIFT Code: CITIGB2LXXX  
CITIBANK INTERNATIONAL LONDON  
CITIGB2LXXX  
GB

[Reset](#)

Payment Details: Against PO22323

[Add Payment Details](#)

Note (Optional):

80 Characters Left

[Save](#)
[Make a Copy & Save](#)
[Reset Fields](#)

**Payee 2**

Payee: Harriet

HarrietGlo - Harriet		
Account Number	Account Type	Account Name
45454KDTY1TD	Domestic	Harriet LeSance
Bank Details		
HSBLGB99,HSBC BANK LONDON, Corporate Park Avenue, London 789911, GB		

Transfer From: xxxxxxxxxxxx0040

Balance: £2,988,750.00

Amount: GBP €1,000.00 [View Limits](#)

Transfer When:  Now  Later

Originators Identification Number: 93222

OIN Description: Originator 1

Purpose: Transaction is an intra-company payment.

Note (Optional):

80 Characters Left

[Save](#)
[Make a Copy & Save](#)
[Reset Fields](#)

[Add Another Payment](#)
[Submit](#)
[Cancel](#)

[Back to Dashboard](#)

**What are the benefits?**

Paying multiple payees at once is easy with the Zigbank Multiple Transfers service. You can specify details for each transfer record and to save additional time, copy the details of one record on to the next.

You can select different accounts from which you want funds transferred to each payee and also select different dates on which each transfer is to be made.

## Field Description

Field Name	Description
<p>The following fields are applicable for each individual transfer record that comprises the multiple transfers transaction:</p>	
<b>Payee Record Number</b>	The payee record number appears on the top of each record so as to identify the number of payees being added.
<b>Payee</b>	Select the payee to whom funds transfer needs to be made. Each payee is identified by the payee nick name defined at the time of payee registration. Once a payee has been selected, the details of the payee including the payee nickname, account number, account type, etc. will be displayed on the screen.
<b>Account Number</b>	On selecting the payee, the account number associated with the payee appears.
<b>Account Type</b>	The type of account or transfer type associated with the payee appears, once a payee is selected.
<b>Account Name</b>	The name of the payee in the bank account appears.
<b>Payee Address</b>	Address of the payee in the bank account. This field appears for <b>International</b> type of payee.
<b>Bank Details</b>	The details of the bank i.e. the name and address of the bank's branch in which the payee's account is held appears.
<b>Transfer From</b>	Select the source account from which the funds are to be transferred.
<b>Balance</b>	On selecting a source account, the net balance of the account appears below the <b>Transfer From</b> field.
<b>Currency</b>	Select the currency in which the transfer is to take place. Currency is defaulted to destination account currency for Internal Transfers and local currency for Domestic Transfers. For International transfers, the user can select the currency from the list.
<b>Amount</b>	Specify the amount to be transferred.
<b>View Limits</b>	Link to view the transaction limits applicable to the user.

Field Name	Description
<b>Transfer When</b>	<p>The facility to specify when the funds are to be transferred.</p> <p>The options are:</p> <ul style="list-style-type: none"> <li>• Now: transfer funds on the same day</li> <li>• Later: transfer funds on a future date</li> </ul>
<b>Transfer Date</b>	<p>The date on which the transfer is to take place.</p> <p>This field appears if the option <b>Later</b> is selected from the <b>Transfer When</b> list.</p>
<b>Originators Identification Number</b>	<p>The Originator's Identification Number is the unique number given to participants who are authorized to use the Direct Debit Scheme.</p> <p>This field appears if you select <b>Domestic</b> type of payee from the Payee list.</p>
<b>OIN Description</b>	<p>A brief description of the OIN.</p> <p>This field appears if you select <b>Domestic</b> type of payee from the Payee list.</p>
<b>Purpose</b>	<p>Select the purpose of the transfer.</p> <p>If purpose of transfer is selected as 'Other, an additional field is displayed in which the user can specify a purpose which is not defined in the list.</p> <p>This field appears against a record where the transfer is being made towards either an <b>Internal</b> or <b>Domestic</b> payee.</p>
<b>Correspondence Charges</b>	<p>The facility to select the party by whom transfer charges are to be borne.</p> <p>The options are:</p> <ul style="list-style-type: none"> <li>• Payee: transfer charges are to be borne by the beneficiary</li> <li>• Payer: transfer charges are to be borne by the ordering customer</li> <li>• Shared: transfer charges are to be borne by both the payee and payer</li> </ul> <p>This field appears against a record where the transfer is being made towards an <b>International</b> payee.</p>
<b>Transfer via Intermediary Bank</b>	<p>Specify whether the fund transfer is to be done through intermediary bank.</p> <p>This field appears only for <b>International</b> Payee.</p>



Field Name	Description
<b>Pay Via</b>	<p>Network for payment.</p> <p>The options are:</p> <ul style="list-style-type: none"> <li>• Swift Code</li> <li>• NCC (National Clearing code)</li> <li>• Bank Details</li> </ul> <p>This field appears if you select Yes option from <b>Transfer via Intermediary Bank</b> field.</p>
<b>SWIFT / National clearing code value</b>	SWIFT code /National Clearing code value.
<b>SWIFT code Look up</b>	
Below fields appears if the <b>SWIFT Code</b> option is selected in <b>Pay Via</b> field.	
<b>Lookup Swift Code</b>	Link to search the SWIFT code.
<b>SWIFT Code</b>	SWIFT code value.
<b>Bank Name</b>	Bank name to search the SWIFT code.
<b>Country</b>	Country name to search the SWIFT code.
<b>City</b>	City name to search the SWIFT code.
<b>SWIFT code Lookup - Search Result</b>	
<b>Bank Name</b>	Name of the bank.
<b>Address</b>	Displays complete address of the bank.
<b>SWIFT Code</b>	SWIFT code /National Clearing code value.
<b>National clearing code Look up</b>	
Below fields appears if the <b>National clearing code</b> option is selected in <b>Pay Via</b> field.	
<b>Lookup National clearing code</b>	Link to search the National clearing code.
<b>NCC Type</b>	NCC type of the bank branch.
<b>NCC Code</b>	NCC code of the bank branch.
<b>Bank Name</b>	Name of the bank.
<b>City</b>	City to which the bank belongs.
<b>NCC Lookup - Search Result</b>	

Field Name	Description
<b>Bank Name</b>	Name of the bank.
<b>Branch</b>	Bank branch name.
<b>Address</b>	Address of the bank.
<b>NCC Code</b>	NCC code of the bank branch.
Below fields appears if the <b>Bank Details</b> option is selected in <b>Pay Via</b> field.	
<b>Bank Name</b>	Name of the bank.
<b>Bank address</b>	Complete address of the bank.
<b>Country</b>	Country of the bank.
<b>City</b>	City to which the bank belongs.
<b>Payment Details</b>	Specify payment details. This field appears against a record where the transfer is being made towards an <b>International</b> payee.
<b>Add Payment Details</b>	The link to add more details of the transfer. This field appears only for <b>International</b> Payee.
<b>Note</b>	Narrative for the transaction.

#### To transfer funds to multiple payees:

- From the **Payee** list, select the preferred payee, and subsequently select the specific account of the payee towards which the transfer is to be made.  
The details of the selected payee appear.  
OR  
Click  if you want to select a different payee.
- From the **Transfer From** account list, select the account from which the transfer is to be made.
- From the **Currency** list, select the preferred currency.
- In the **Amount** field, enter the transfer amount.  
OR  
Click the **View Limits** link to check the transfer limit.
- In the **Transfer When** field, select the option to indicate when the transfer is to take place.
  - If you select the **Now** option, the transfer will be made on the same day.  
OR
  - If you select the option **Later** in the **Transfer When** field, select the appropriate future date for when the transfer is to take place.



6. If the transfer type is **Internal**, select the appropriate purpose of transfer from the **Purpose** list.  
OR  
If the transfer type is **Domestic**:
  - a. In the **Originators Identification Number** field, enter the identification number of the originator.
  - b. In the **OIN Description** field, enter the description for the OIN.
  - c. From the **Purpose** list, select the appropriate purpose of transfer.
 OR  
If the transfer type is **International**,
  - a. From the Correspondence Charges list, select the appropriate option.
  - b. In the **Transfer via Intermediary Bank** field, select the appropriate option.
  - c. If you have selected **Yes** option in the **Transfer via Intermediary Bank** field, select the appropriate network for payment in the **Pay Via** field.
    1. If you select **Swift** option:
      - i. In the **SWIFT code** field, enter the SWIFT code or search and select it from the lookup.
      - ii. Click **Verify** to fetch bank details based on Bank Code (BIC).
    2. If you select **National Clearing code** option:
      - i. In the **National Clearing code** field, enter the National Clearing code or search and select it from the lookup.
      - ii. Click **Verify** to fetch bank details based on Bank Code (BIC).
    3. If you select **Bank details** option:
      - i. In the **Bank Name** field, enter the bank name.
      - ii. In the **Bank Address** field, enter the complete address of the bank.
      - iii. From the **Country** list, select the country of the bank.
      - iv. From the **City** list, select the city to which the bank belongs.
  - d. In the **Payment Details** field, enter the details about the fund transfer.
7. Click **Save** to save the transfer record.  
OR  
Click **Make a Copy & Save**, if you want to save the current record and also copy the details onto the next record.  
OR  
Click **Reset Fields** to clear the details entered in the record.
8. Repeat Steps 1 to 7 for subsequent transfer records.  
OR  
Click **Add Another Payment** if you want to add another transfer record without saving the current record.
9. Click  against a saved record to edit the transfer details of that record.  
OR  
Click  against a record to delete that record.  
OR  
Click **Add Another Payment** if you want to add another payment details.

10. Click **Submit** to submit all the transfer records to the bank.  
OR  
Click **Cancel** to cancel the operation and to navigate back to 'Dashboard'.  
OR  
Click **Back to Dashboard** link, to navigate to the dashboard.
11. The **Multiple Transfer - Review** screen appears. Verify the details, and click **Confirm**.  
OR  
Click **Expand All** to view the details of each transfer record.  
Click **Collapse All** to hide the payment details.  
OR  
Click **Back to navigate** back to the previous screen.  
OR  
Click **Cancel** to cancel the operation and navigate back to 'Dashboard'.
12. The **Verification** screen appears if the transaction is configured for Two Factor Authentication.  
Enter the verification code and click **Submit**.
13. The success message appears.  
Click **Go to Dashboard**, to navigate to the dashboard.  
OR  
Click **More Payment Options** to access other payment options.  
OR  
Click **Status** to view the status of each transfer.  
The **Multiple Transfer – Status** screen appears on which the status of each individual transfer appears. In case any transfer has failed, the reason for failure is also displayed against the specific record.

### Multiple Transfers – Status

Payee	From Account	Date & Amount	Host Reference No.	Status	Failure Reason
Harriet 45454KDTYITD	xxxxxxxxxxxx0040	03 Jan 2014 £100.00	–	Failed	
Jack AT30025430013	xxxxxxxxxxxx0040	03 Jan 2014 €1,000.00	AT3FTOC14003D35Z	Completed	NA

[Back to Dashboard](#)

**Field Description**

<b>Field Name</b>	<b>Description</b>
<b>Payee</b>	The payee towards whom fund transfer has been initiated. The payee nickname along with the payee's account number are displayed.
<b>From Account</b>	The source account from which the funds are transferred.
<b>Date &amp; Amount</b>	The date of transfer along with the amount that is transferred towards the payee's account.
<b>Host Reference Number</b>	The unique number generated on completion of the transaction in the Core Banking application.
<b>Status</b>	The status of the transaction.
<b>Failure Reason</b>	The reason for which a transfer failed is displayed against the specific transfer record.

14. Click the [\*\*Back to Dashboard\*\*](#) link to navigate to the Dashboard.

## **FAQs**

**1. Is there any limit on the number of payments that can be initiated at a time through multiple transfers?**

Yes, the limit as defined by the bank will be in place. You will be displayed an error message if you try to add another transfer record once this limit has been met.

**2. Do fund transfers between business accounts need authorization?**

Fund transfer between the business accounts require authorization, if transaction is configured for Two Factor Authentication.

**3. How long will it take to transfer funds between the accounts?**

Fund transfer between your own accounts occurs instantly, where as it takes 2-5 business days to transfer the funds to International accounts.

**4. Is there a transfer limit applicable for Multiple Transfers?**

There is no limit on the amount you can transfer between your own accounts. However a daily limit applies to all other transfers.

[Home](#)

## 6. Adhoc Transfer

An adhoc transfer is one which is used to transfer funds from the user's account to a beneficiary/payee account which is not registered with the bank. Since the transfer is towards an unregistered beneficiary, customers are required to specify the beneficiary details manually along with the transfer details while initiating an adhoc transfer.

### Pre-Requisites

- Transaction and account access is provided to retail user.
- Transaction working window is maintained.
- Transaction limits are assigned to user to perform the transaction.

### Workflow

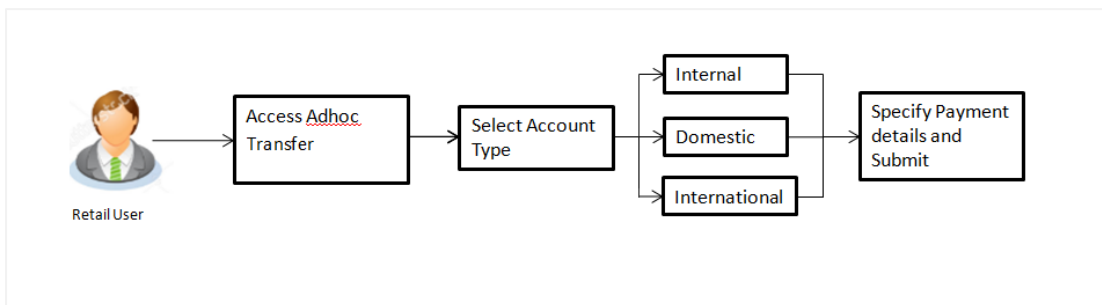

### Features Supported In Application

Following type of transactions are supported under Adhoc Transfers

- Internal Transfer
- Domestic Transfer
- International Transfer

### How to reach here:

*Dashboard > Toggle menu > Payments > Adhoc Transfer> Adhoc Transfer*

*OR*

*Dashboard > Quick Links > Adhoc Transfer*

## 6.1 Adhoc Payment - Internal Fund Transfer

An Internal Bank Account transfer is a transfer to an account which is maintained within the Bank. Basic payee details i.e. the name of the payee and payee account number are captured. In addition to the payee details, the user is also required to specify transfer specific details while initiating an adhoc internal transfer. The user can also view the transaction limits associated with a current transaction.

### Internal fund transfer

The screenshot shows the 'Adhoc Internal Transfer' page in the ZigBank interface. The page has a dark blue header with the ZigBank logo and navigation links for Dashboard, Trends, and Payments. A search icon, a notification bell with '78', and a Logout button are on the right. Below the header, there's a breadcrumb trail: Favorites > Transfer Money > Adhoc Transfer > Multiple Transfers > Issue Demand Drafts > Upcoming Payments > Pay Bills > Multiple Bill >. The main form area is titled 'Adhoc Internal Transfer' and contains several sections: 'Account Type' with buttons for 'Internal', 'Domestic', and 'International'; 'Account Number' with the value 'AT30009610028'; 'Account Name' with the value 'Raem'; 'Transfer From' with a masked account number 'XXXXXXXXXXXX0333' and a dropdown arrow; 'Balance' showing '£850.00'; 'Amount' with a currency selector set to 'GBP' and a value of '£50.00', plus a 'View Limits' link; 'Transfer When' with radio buttons for 'Now' (selected) and 'Later'; 'Purpose' with a dropdown menu showing 'Transaction is the payment of di...'; and 'Note (Optional)' with a text input field and '80 Characters Left' indicator. At the bottom of the form are 'Pay' and 'Cancel' buttons. A 'Back to Dashboard' link is at the bottom left. On the right side, there's a box titled 'What are the benefits?' with a crown icon and text explaining that users can transfer money to any bank account by specifying the account number and supporting bank and branch information, and that the service also allows registering payees for future use.

### Field Description

Field Name	Description
Account Type	Type of account associated with the payee. The options available are: <ul style="list-style-type: none"> <li>Internal</li> <li>Domestic</li> <li>International</li> </ul>

Field Name	Description
<b>Account Number</b>	Account number of the payee.
<b>Account Name</b>	Name of the payee as defined against the bank account.
<b>Transfer From</b>	Source account from which the funds are to be transferred. The account nickname, if the user has set a nickname for the account, it will be displayed.
<b>Balance</b>	Net balance in the selected source account.
<b>Amount</b>	Amount to be transferred along with the currency.
<b>View Limits</b>	Link to view the transaction limits of the user.
<b>Transfer When</b>	Option to specify when the funds are to be transferred. The options are: <ul style="list-style-type: none"> <li>• Now: transfer funds on the same day</li> <li>• Later: transfer funds on a future date</li> </ul>
<b>Transfer Date</b>	Date of transfer. This field appears if the option <b>Later</b> from the <b>Transfer When</b> list is selected.
<b>Purpose</b>	Purpose of transfer.
<b>Note</b>	Narrative for the transaction.

**To initiate an internal fund transfer:**

1. In the **Account Type** field, select the **Internal** option as type of account associated with the payee.
2. In the **Account Number** field, enter the payee's account number.
3. In the **Account Name** field, enter the payee name.
4. From the **Transfer From** account list, select the account from which transfer needs to be made.
5. In the **Amount** field, enter the transfer amount.
6. In the **Transfer when** field, select the option to indicate when the transfer is to take place.
7. If you select the **Now** option, the transfer will be made on the same day.  
OR  
If you select the option **Later** in the **Transfer when** field, select the appropriate future date when the transfer is to take place.
8. From the **Purpose** list, select the appropriate purpose of transfer.

9. Click **Pay** to initiate the transfer.  
OR  
Click **Cancel** to cancel the transaction.  
OR  
Click the **Back to Dashboard** link, to navigate to the dashboard.
10. The **Review** screen appears. Verify the details, and click Confirm.  
OR  
Click **Back** to navigate back to the previous screen.  
OR  
Click **Cancel** to cancel the transaction.  
The user is directed to **Adhoc Internal Transfer** screen with values in editable form.
11. The success message appears, along with the reference number and payment details.  
Click **Go To Dashboard** to go to the **Dashboard** screen.  
OR  
Click **More Payment Options** to access the other payments options.  
OR  
Click **Add as Payee?** to register the beneficiary as a payee.



## 6.2 Adhoc Payment - Domestic Fund Transfer

A domestic transfer is one which involves the transfer of funds to an account held with another bank within the same country. In addition to the payee name and payee account number, the customer is also required to specify details of the bank in which the payee's account is held along with the mode/network of transfer. The customer must also specify transfer specific details including when the transfer is to take place and the purpose of the transfer.

### Domestic fund transfer

**ZigBank** Dashboard Trends Payments

Adhoc Domestic Payment

Account Type:  Internal  Domestic  International

Account Number: AT30025430013

Account Name: Raem

Pay Via:  NEFT  RTGS  IMPS

IFSC Code: HDFC0000017  
 HDFC Bank Ltd  
 361, Saks Avenue  
 Chennai  
 HDFC0000017

Reset

Transfer From: xxxxxxxxxxxx0333  
 Balance: £850.00

Amount: GBP £50.00  
[View Limits](#)

Transfer When:  Now  Later

Purpose: Credit Card Payment

Note (Optional): 80 Character's Left

Pay Cancel

[Back to Dashboard](#)

**What are the benefits?**

Transfer money to any bank account by simply specifying the account number and supporting bank and branch information. You can transfer money to accounts held within Zigbank as well as to other bank accounts held both within the country and internationally.

The Adhoc Transfer service also allows you to register your payee for future use, once you have made the transfer.

Copyright © 2006, 2017, Oracle and/or its affiliates. All rights reserved. | Security Information | Terms and Conditions

## Field Description

Field Name	Description
<b>Account Type</b>	Type of account associated with the payee. The options available are: <ul style="list-style-type: none"> <li>• Internal</li> <li>• Domestic</li> <li>• International</li> </ul>
<b>Account Number</b>	Account number of the payee.
<b>Account Name</b>	Name of the payee as defined against bank account.
<b>Pay Via</b>	Network for payment. Domestic Networks are configurable – NEFT / RTGS / IMPS get displayed as per India region configuration.
<b>IFSC /Bank Code</b>	IFSC /Bank Code of destination bank.
<b>Bank Details</b>	Bank details based on the IFSC code of the bank. It includes: <ul style="list-style-type: none"> <li>• Bank Name</li> <li>• Bank Address</li> <li>• City and State to which the bank belongs.</li> </ul>
<b>Transfer From</b>	Source account from which the funds are to be transferred.
<b>Balance</b>	Net balance in the selected source account.
<b>Amount</b>	Amount to be transferred along with the currency.
<b>View Limits</b>	Link to view the transaction limits of the user.
<b>Transfer When</b>	The facility to specify when the funds are to be transferred The options are: <ul style="list-style-type: none"> <li>• Now: transfer funds on the same day</li> <li>• Later: transfer funds on a future date</li> </ul>
<b>Transfer Date</b>	Date of transfer. This field appears if option <b>Later</b> from the <b>Transfer When</b> list is selected.
<b>Purpose</b>	Purpose of transfer.

Field Name	Description
------------	-------------

<b>Note</b>	Narrative for the transaction.
-------------	--------------------------------

**To initiate domestic fund transfer:**

1. In the **Account Type** field, select the **Domestic** option as type of account associated with the payee.
2. In the **Account Number** field, enter the payee's account number.
3. In the **Account Name** field, enter the payee name.
4. In the **Pay Via** field, select the appropriate network for payment.
5. In the **IFSC Code** field, enter the **IFSC /Bank Code** or select it from the lookup.
6. Click **Verify** to fetch bank details based on Bank Code (BIC).
7. From the **Transfer From** account list, select the account from which the transfer needs to be made.
8. In the **Amount** field, enter the transfer amount.
9. In the **Transfer When** field, select the option to indicate when the transfer is to take place.
  - a. If you select the **Now** option, transfer will be made on the same day.  
OR  
If you select the option **Later** in the Transfer when field, select the appropriate future date when the transfer is to take place.
10. From the **Purpose** list, select the appropriate purpose of transfer.
11. Click **Pay**.  
OR  
Click **Cancel** to cancel the transaction.  
OR  
Click the **Back to Dashboard** link, to navigate to the dashboard.
12. The **Review** screen appears. Verify the details, and click **Confirm**.  
OR  
Click **Back** to navigate back to the previous screen.  
OR  
Click **Cancel**. The user is directed to the **Adhoc Domestic Transfer** – screen with values in editable form.
13. The success message appears, along with the reference number and payment details.  
Click **Go To Dashboard** to go to the **Dashboard** screen.  
OR  
Click **More Payment Options** to access the other payments options.  
OR  
Click **Add as Payee?** to register the beneficiary as a payee.

### **6.3 Adhoc Payment - International Fund Transfer**

An international fund transfer involves the transfer of funds to an account that is maintained outside the country and beyond geographical boundaries. While initiating an adhoc international fund transfer, the customer is required to specify payee details which include the payee account number, clearing code of the bank in which the payee's account is held along with the network through which the transfer is to be processed. Details specific to the transfer type must also be defined which include identifying the party who is to bear correspondence charges and defining payment details.

## International fund transfer

 Dashboard Trends Payments 🔍 📧 9 🔌 Logout

### Adhoc International Payment

Favorites Transfer Money **Adhoc Transfer** Multiple Transfers Issue Demand Drafts Upcoming Payments Pay Bills Multipl >

Account Type

Account Number  
AT30025430013

Account Name  
Michael Frost

Address Line 1  
401 Island Parkway

Address Line 2  
Redwood Shores,

City  
CA 94065

Country  
UNITED STATES

Pay Via  
 SWIFT Code  NCC  Bank Details

SWIFT Code  
AKBKG22XXX  
AKBANK NV LONDON BRANCH  
2ND FLOOR:  
LONDON  
GB

Transfer From  
xxxxxxxxxxxx0040

Balance: £2,998,667.78

Amount  
EUR €1,000.00  
[View Limits](#)

Transfer When  
 Now  Later

Correspondence Charges  
SHARED

Transfer via Intermediary Bank  
 Yes  No

Pay Via  
 SWIFT Code  NCC  Bank Details

SWIFT Code  
CITI62LXXX  
CITIBANK INTERNATIONAL LONDON  
CITI62LXXX  
GB

Payment Details  
Against POE89022  
[Add Payment Details](#)

Note (Optional)  
80 Characters Left

[Back to Dashboard](#)

### What are the benefits?

Transfer money to any bank account by simply specifying the account number and supporting bank and branch information. You can transfer money to accounts held within Zigbank as well as to other bank accounts held both within the country and internationally.

The Adhoc Transfer service also allows you to register your payee for future use, once you have made the transfer.

## Field Description

Field Name	Description
<b>Account Type</b>	Type of account associated with the payee. The type can be: <ul style="list-style-type: none"> <li>• Internal</li> <li>• Domestic</li> <li>• International</li> </ul>
<b>Account Number</b>	Account number of the payee.
<b>Account Name</b>	Name of the payee as defined against bank account
Address Line 1- 2	Address of the payee.
City	City of the payee.
Country	Country of the payee.
<b>Pay Via</b>	The network/mode through which the transfer is to take place. The options are: <ul style="list-style-type: none"> <li>• SWIFT Code</li> <li>• NCC (National Clearing code)</li> <li>• Bank Details</li> </ul>
<b>SWIFT Code</b>	The SWIFT code will need to be identified if <b>SWIFT Code</b> has been selected in the <b>Pay Via</b> field.
<b>Lookup Swift Code</b>	Link to search the SWIFT code.
<b>SWIFT code Look up</b>	
The following fields appear on a pop up window if the <b>Lookup SWIFT Code</b> link is selected.	
<b>SWIFT Code</b>	The facility to lookup bank details based on SWIFT code.
<b>Bank Name</b>	The facility to search for the SWIFT code based on the bank name.
<b>Country</b>	The facility to search for the SWIFT code based on the country.
<b>City</b>	The facility to search for the SWIFT code based on city.
<b>SWIFT Code Lookup - Search Result</b>	

Field Name	Description
<b>Bank Name</b>	Name of the bank.
<b>Address</b>	Displays complete address of the bank.
<b>SWIFT Code</b>	SWIFT code /National Clearing code value as identified.

#### National clearing code Look up

The following fields appear on a pop up window if the **Lookup National Clearing Code** link is selected.

**Lookup National Clearing Code** Link to search the national clearing code.

<b>NCC Type</b>	The facility to search for the national clearing code by type.
<b>NCC Code</b>	The facility to search for bank details by defining the national clearing code.
<b>Bank Name</b>	The facility to search for the national clearing code by defining the name of the bank.
<b>City</b>	The facility to search for the national clearing code by city.

#### NCC Lookup - Search Result

<b>Bank Name</b>	Name of the bank.
<b>Branch</b>	Bank branch name.
<b>Address</b>	Displays complete address of the bank.
<b>NCC Code</b>	NCC code of the bank branch.

The following fields appear if the option, **Bank Details** is selected in **Pay Via** field.

<b>Bank Name</b>	Name of the bank in which the payee account is held.
<b>Bank address</b>	Complete address of the bank at which the payee account is held.
<b>Country</b>	Country of the bank.
<b>City</b>	City to which the bank belongs.
<b>Transfer From</b>	Source account from which the funds are to be transferred.
<b>Balance</b>	Net balance in the selected source account.
<b>Amount</b>	Amount to be transferred along with the currency.

Field Name	Description
<b>View Limits</b>	Link to view the transaction limits of the user.
<b>Transfer When</b>	<p>The facility to specify when the transfer is to take place.</p> <p>The options are:</p> <ul style="list-style-type: none"> <li>• Now: transfer funds on the same day</li> <li>• Later: transfer funds on a future date</li> </ul>
<b>Transfer Date</b>	<p>Date of transfer.</p> <p>This field appears if the option <b>Later</b> is selected from the Transfer When list.</p>
<b>Correspondence Charges</b>	<p>The facility to select the party by whom transfer charges are to be borne.</p> <p>The options are:</p> <ul style="list-style-type: none"> <li>• Payee: transfer charges are to be borne by the beneficiary customer</li> <li>• Payer: transfer charges are to be borne by the ordering customer</li> <li>• Shared: transfer charges are to be borne by both the payee and the payer</li> </ul> <hr/> <p><b>Note:</b> This field appears only for International transfer.</p> <hr/>
<b>Transfer via Intermediary Bank</b>	<p>Specify whether the fund transfer is to be done through intermediary bank.</p> <p>This field appears only for <b>International</b> Payee.</p>
<b>Pay Via</b>	<p>The network/ mode through which the transfer is to take place. The options are:</p> <ul style="list-style-type: none"> <li>• SWIFT Code</li> <li>• NCC (National Clearing code)</li> <li>• Bank Details</li> </ul>
<b>SWIFT Code</b>	The SWIFT code will need to be identified if SWIFT Code has been selected in the Pay Via field.
<b>Lookup Swift Code</b>	Link to search the SWIFT code.
<b>SWIFT code Look up</b>	The following fields appear on a pop up window if the <b>Lookup SWIFT Code</b> link is selected.
<b>SWIFT Code</b>	



<b>Field Name</b>	<b>Description</b>
<b>Bank Name</b>	The facility to search for the SWIFT code based on the bank name.
<b>Country</b>	The facility to search for the SWIFT code based on the country.
<b>City</b>	The facility to search for the SWIFT code based on the city.
<b>SWIFT Code Lookup - Search Result</b>	
<b>Bank Name</b>	Name of the bank.
<b>Address</b>	Displays complete address of the bank.
<b>SWIFT Code</b>	SWIFT code /National Clearing code value.
<b>National clearing code Look up</b>	
Below fields appears if the <b>National clearing code</b> option is selected in <b>Pay Via</b> field.	
<b>Lookup National clearing code</b>	Link to search the National clearing code.
<b>NCC Type</b>	NCC type of the bank branch.
<b>NCC Code</b>	NCC code of the bank branch.
<b>Bank Name</b>	Name of the bank.
<b>City</b>	City to which the bank belongs.
<b>NCC Lookup - Search Result</b>	
<b>Bank Name</b>	Name of the bank.
<b>Branch</b>	Bank branch name.
<b>Address</b>	Address of the bank.
<b>NCC Code</b>	NCC code of the bank branch.
Below fields appears if the <b>Bank Details</b> option is selected in <b>Pay Via</b> field.	
<b>Bank Details</b>	Bank details based on the Swift / National clearing code selected for the bank.
<b>Bank Name</b>	Name of the bank.
<b>Bank address</b>	Complete address of the bank.
<b>Country</b>	Country of the bank.

Field Name	Description
<b>City</b>	City to which the bank belongs.
<b>Payment Details</b>	Details about the fund transfer.
<b>Add Payment Details</b>	The link to add more details of the transfer.
<b>Note</b>	Narrative for the transaction.

#### To initiate an international fund transfer:

1. In the **Account Type** field, select the International option as type of account associated with the payee.
2. In the **Account Number** field, enter the payee's account number.
3. In the **Account Name** field, enter the payee name.
4. In the **Pay Via** field, select the appropriate network for payment.
  - a. If you select the **Swift** option:
    - i. In the **SWIFT code** field, enter the SWIFT code or search the SWIFT code through the lookup option provided.
    - ii. Click **Verify** to fetch bank details based on SWIFT Code.
  - b. If you select **National Clearing code** option:
    - i. In the **National Clearing code** field, enter the National Clearing code search the National Clearing Code through the lookup option provided.
    - ii. Click **Verify** to fetch bank details based on National Clearing Code.
  - c. If you select **Bank** details option:
    - i. In the **Bank Name** field, enter the bank name.
    - ii. In the **Bank Address** field, enter the complete address of the bank.
    - iii. From the **Country** list, select the country of the bank.
    - iv. From the **City** list, select the city to which the bank belongs.
5. From the **Transfer From** account list, select the account from which the transfer needs to be made.
6. In the **Amount** field, enter the transfer amount and currency in which the transfer is to take place.
7. In the **Transfer when** field, select the option to indicate when the transfer is to take place.
  - a. If you select the **Now** option, transfer will be made on the same day.  
OR
  - b. If you select the option **Later** in the Transfer when field, select the appropriate future date when the transfer is to take place.
8. From the **Correspondence Charges** list, select the party by whom the transfer charges are to be borne.
9. In the **Transfer via Intermediary Bank** field, select the appropriate option.

10. If you have selected **Yes** option in the **Transfer via Intermediary Bank** field, select the appropriate network for payment in the **Pay Via** field.
- a. If you select **Swift** option:
    - i. In the **SWIFT code** field, enter the SWIFT code or search and select it from the lookup.
    - ii. Click **Verify** to fetch bank details based on Bank Code (BIC).
  - b. If you select **National Clearing code** option:
    - i. In the **National Clearing code** field, enter the National Clearing code or search and select it from the lookup.
    - ii. Click **Verify** to fetch bank details based on Bank Code (BIC).
  - c. If you select **Bank details** option:
    - i. In the **Bank Name** field, enter the bank name.
    - ii. In the **Bank Address** field, enter the complete address of the bank.
    - iii. From the **Country** list, select the country of the bank.
    - iv. From the **City** list, select the city to which the bank belongs.
11. In the **Payment Details** field, enter the details about the fund transfer.
12. Click **Pay**.  
OR  
Click **Cancel** to cancel the transaction.  
OR  
Click the **Back to Dashboard** link, to navigate to the dashboard.
13. The **Review** screen appears. Verify the details, and click **Confirm**.  
OR  
Click **Back** to navigate back to the previous screen.  
OR  
Click **Cancel**. The user is directed to the **Adhoc International Transfer** screen with values in editable form.
14. The success message appears, appears along with the host reference number, UETR number (Unique End-to-End Transaction Reference), Transfer To, Amount, Account Number, Account Type, Bank Details, Payment Details, Transfer From, Transfer When, Pay Via, Payee Address and Intermediary Bank Details.  
Click **Go To Dashboard** to go to the **Dashboard** screen.  
OR  
Click **More Payment Options** to access the other payments options.  
OR  
Click **Add as Payee?** to register the beneficiary as a payee.

### Success Message

**ZigBank** Dashboard Trends Payments 🔍 📧 9 🔌 Logout

### Adhoc International Payment

✔ Your transaction is successful!  
Host Reference Number AT3FTOC14003D1MM

UETR  
3b3c9e38-5c7a-44b5-a4b3-38ff7f810b18



Transfer To Michael Frost	Amount €1,000.00
Account Number AT30025430013	Account Type International
Bank Details AKBKGB22XXX,AKBANK NV LONDON BRANCH, LONDON, GB	Payment Details Against POE432323
Transfer From xxxxxxxxxxxx0040	Transfer When 03 Jan 2014

Pay Via  
SWI

Intermediary Bank Details  
CITIGB2LXXX, CITIBANK INTERNATIONAL  
LONDON, GB

Payee Address  
401 Island Parkway, Redwood Shores, CA  
94065, UNITED STATES

What would you like to do next?

 [Go To Dashboard](#)
 [More Payment Options](#)
 [Add as Payee?](#)

Copyright © 2006, 2017, Oracle and/or its affiliates. All rights reserved. | Security Information | Terms and Conditions

15. Click **Add Payee** option to register the beneficiary as a payee.

A pop up window appears on which you can identify whether the beneficiary details are to be mapped to an existing payee or whether the beneficiary is to be registered as a new payee.

## Add Payee - Addition of New Payee

The screenshot displays the ZigBank interface. At the top, there is a navigation bar with 'Dashboard', 'Trends', and 'Payments' links, along with search, notification, and logout icons. The main content area shows a successful transaction confirmation for an 'Adhoc International Payment' with a host reference number AT3FTOC14003D1MM. Below this, there are details for a UETR, transfer to Michael Frost for €1,000, account number AT30025430013, and bank details for Citibank International. A modal dialog box titled 'Add Payee' is open, asking the user to 'Add to an Existing Payee or create a New Payee?'. The 'Existing Payee' option is selected with a radio button. Below this, there is a dropdown menu for 'Payee' with the text 'Please Select' and an 'Ok' button at the bottom.

16. Select the desired option under the field **Add to an Existing Payee or create a New Payee?**
17. If you select **New Payee** option, the **Add Payee** screen appears in which you can register the beneficiary as a new payee.
18. If you select the **Existing Payee** option, you will be required to select the payee to whom the beneficiary details are to be mapped.
19. Click Ok, the **Add Payee** screen appears with all the beneficiary details pre-populated in the required fields.

---

**Note:** For more information on payee creation, refer the section **Add Payee – Bank Account** in this manual.

---

## **FAQs**

1. **Can I use the adhoc transfer transaction to transfer funds towards the repayment of a loan which I hold in the same bank?**

No, fund transfers can be made only to current or savings account through the adhoc transfer transaction.

2. **Can I set a future date for a fund transfer?**

You can set a future date for a payment using the Pay Later option.

3. **What happens if I have set up a future dated transfer, but don't have enough funds in my account on the transaction date for the transfer?**

Balance check will not be performed at the time of transaction initiation with future date. The transaction will get declined in case of insufficient funds in the account on the given transaction date.

4. **What happens if the transaction amount is less than set Transaction Limit?**

If the transaction amount is less than the minimum limit or more than the maximum transaction limit set by the Bank, the user will not be able to initiate the transfer.

5. **Can I make a payment to an account which is currently not registered as my payee?**

Yes, you can make payments to the accounts which are not registered as payees through the adhoc transfer transaction.

6. **Are separate transaction limits applicable for when I initiate a transfer using Adhoc Transfer and using Transfer Money by selecting a payee?**

Transaction limits are defined based on each payment network. The same limits get utilized if the transaction is initiated from Adhoc Transfer or by using Transfer Money (provided the payment network is the same).

[Home](#)

## 7. Manage Payees

The online banking application enables users to register and maintain payees towards whom payments are to be made frequently or on a regular basis. Payee maintenance is beneficial to users as, it spares the user the effort and time spent to fill out the payee information every time a payment is to be initiated towards the payee's account.

The 'Manage Payee' feature not only enables users to register payees, but also enables them to add accounts to a registered payee and view and edit or delete the accounts of existing payees. Additionally, the user can also initiate a payment from this screen by selecting the option 'Pay' against a specific account of a payee.

Payees can be created and maintained for the following types of transfers:

- **Bank Account Transfers**
  - Internal Bank Account
  - Domestic Bank Account
  - International Bank Account
- **Demand Drafts**
  - Domestic Bank Account
  - International Bank Account

### Pre-Requisites

- Transaction access is provided to the retail user
- Cooling period is defined

### Features Supported In the application

- Create Payee
- View Payee
- Edit Payee
- Delete Payee
- Initiate payment towards a Payee

## Workflow

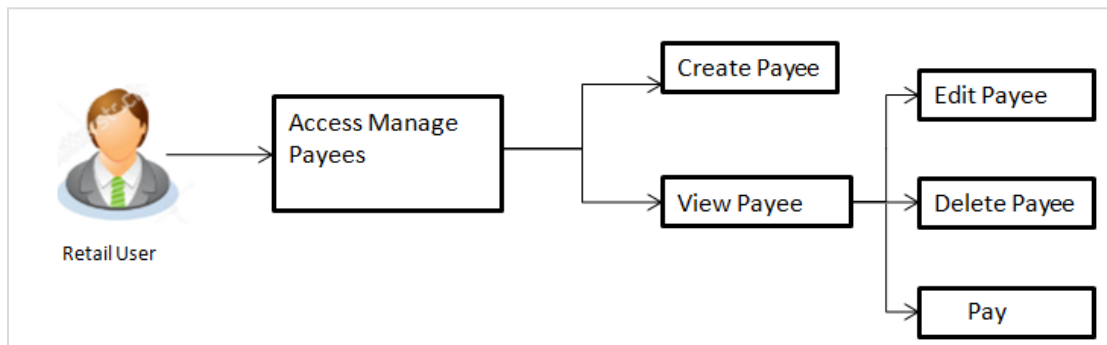

### How to reach here:

*Dashboard > Payments Widget > Manage Payees & Billers*

*OR*

*Dashboard > Toggle Menu > Payments > Manage Payees & Billers*

*OR*

*Dashboard > Payments Menu > Manage Payees & Billers*

## 7.1 Payee Summary

The summarized views of all the Payees maintained by the user are listed on Payee Summary screen. The user is able to search for a specific payee by entering the payee name in the provided search field. The user is able to expand any payee record in order to view the accounts associated with that payee. Subsequently the user is able to view further details of the account associated with the payee and is also able to edit or delete the specific account. The user is also provided with the option to add a new bank account or demand draft to be associated with the payee.

### To manage payees:

1. In the **Manage Whom** field, select the **Payee** option. All the registered payees are listed down by their names defined at the time of payee creation.



## Manage Payees

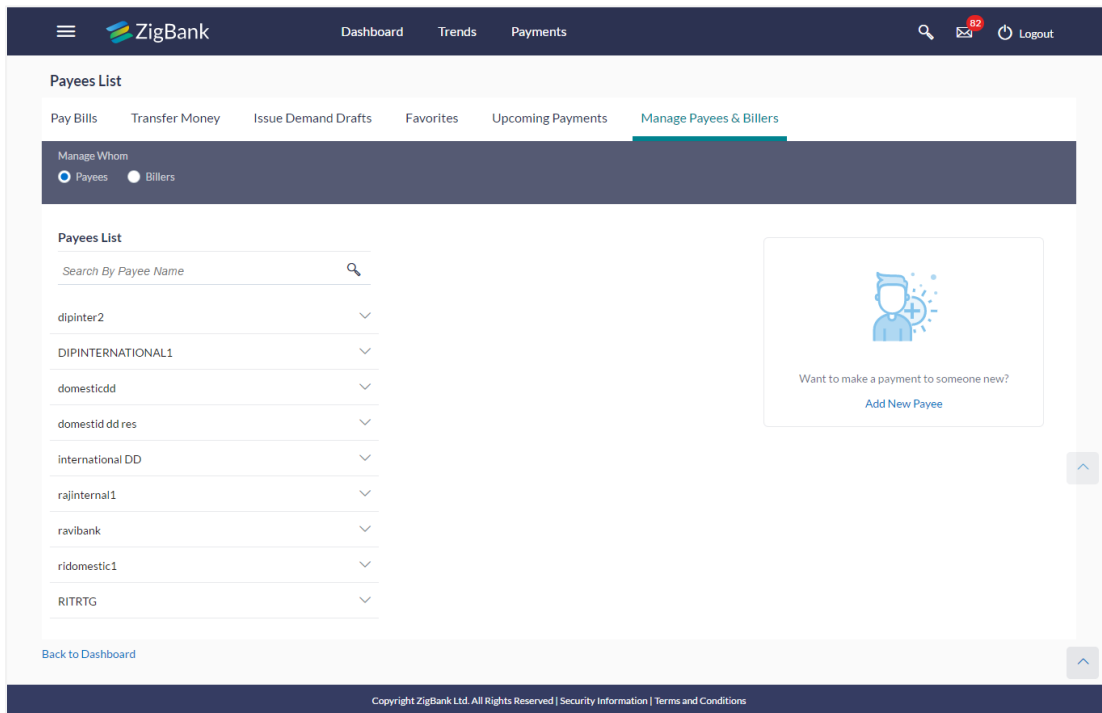



### Field Description

Field Name	Description
<b>Manage Whom</b>	The option to either manage payees or billers.
The following fields appear if the option <b>Payees</b> is selected under the field <b>Manage Whom</b> .	
<b>Payee List</b>	Displays all the payees by their names defined at the time of payee creation.
The following fields appear when the  icon (expand option) is selected against any payee name.	
<b>Account Nickname</b>	All the accounts associated with the specific payee will be listed down by their nickname defined at the time of payee creation or account addition.
<b>Account Type</b>	The type of account that is associated to the payee will be listed down against the nickname.
<b>Add New Account</b>	Link to add a new bank account to be associated with the payee.
<b>Add New Demand Draft</b>	Link to assign demand draft details to the payee.

2. From the **Payee List**, select and click on the payee whose details you want to view.  
OR  
Click  to search for a specific payee whose details you want to view.  
The specific payee record appears.  
OR  
Click **Add New Payee** to create a new payee.

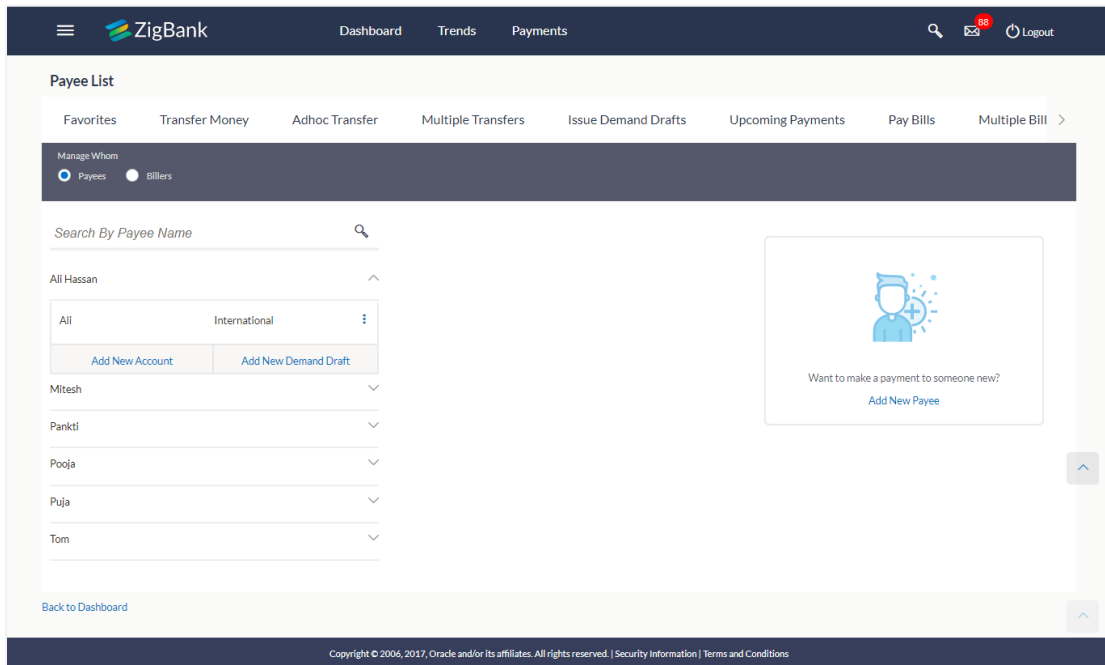
## Manage Payees – Expanded View





3. Click  against a specific account associated with specific payee and then click **View/Edit**.  
The **View / Edit Payee** screen appears.  
OR  
Click **Pay** to transfer funds/ issue demand draft.  
OR  
Click **Delete** to delete the payee.  
OR  
Click the **Add New Account** or **Add New DD** link to add new account type or demand draft type of payee.  
OR  
Click **Back to Dashboard** to navigate back to the dashboard.

## 7.2 View Payee Details

The user is able to view details of the account associated with the payee by selecting the option 'View/Edit' provided against each account record displayed on expansion of a payee record.

**To view payee details:**

1. From the **Payee List**, select and click on the expand option provided against the payee whose details you want to view.  
OR  
Click  to search for a specific payee whose details you want to view.  
A card displaying Payee Name, Payee Type and links to add a new account or new demand draft to the payee appears.
2. Click  and then click the **View/Edit** option. The **View/ Edit Payee** screen appears.

**View/Edit Payee**

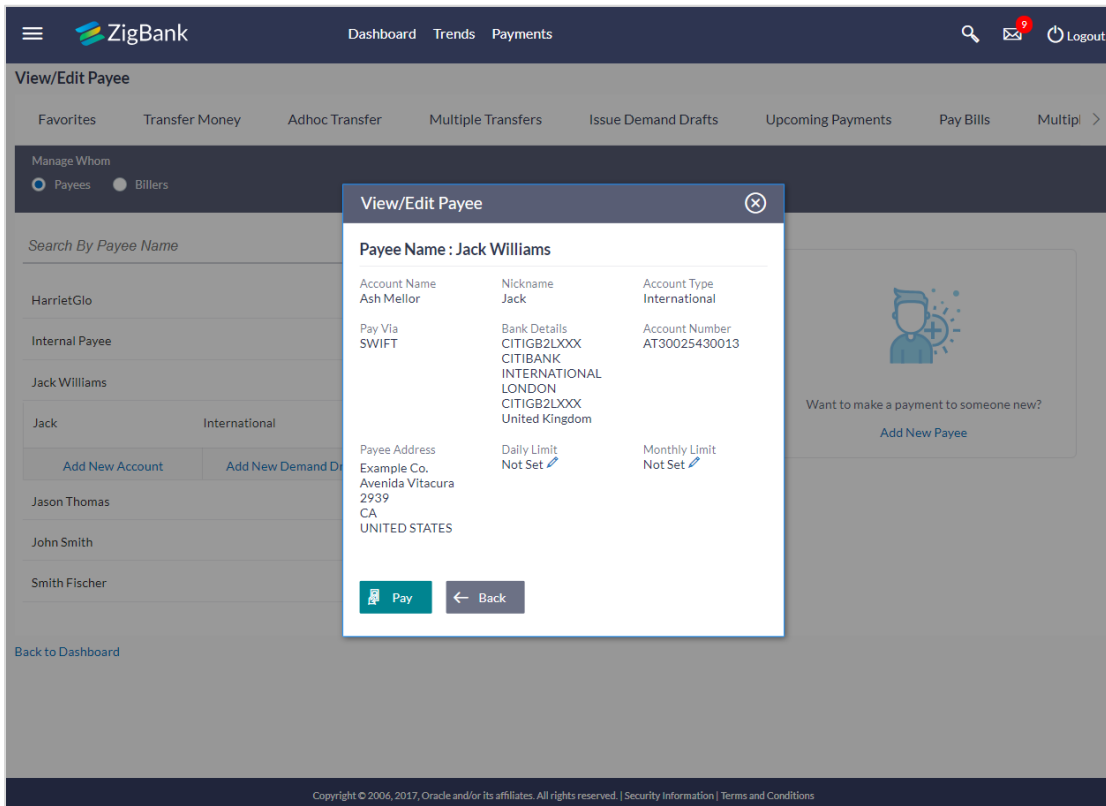

**Field Description**

Field Name	Description
------------	-------------

**Payee Account Details - Bank Account**

The following fields appear if the payee details being viewed are that of a bank account.

<b>Payee Name</b>	Name of the payee.
<b>Account Name</b>	Name of the payee as maintained in the bank account.
<b>Nickname</b>	The nickname assigned to the payee’s account for easy identification.

Field Name	Description
<b>Account Type</b>	The type of account associated with the payee. The account types can be: <ul style="list-style-type: none"> <li>• Internal</li> <li>• Domestic</li> <li>• International</li> </ul>
<b>Pay Via</b>	The network through which funds will be transferred to the payee's bank account. This field appears if the Account Type is <b>Domestic</b> or <b>International</b> .
<b>Bank Details</b>	Details of the payee's bank account which will include the address and bank and branch codes. This field appears if the Account Type is <b>Domestic</b> or <b>International</b> .
<b>Account Number</b>	The bank account number of the payee.
<b>Payee Address</b>	Address of the payee in the bank account. This field appears if the Account Type is <b>International</b> .
<b>Daily Limit</b>	The maximum limit that can be transferred to this account on a daily basis.
<b>Monthly Limit</b>	The maximum limit that can be transferred to this account on a monthly basis.
<b>Payee Account Details – Demand Draft</b>	
The following fields appear if the payee details being viewed are that of a demand draft.	
<b>Payee Name</b>	Name of the payee.
<b>Nickname</b>	The nickname assigned to the payee's demand draft maintenance for easy identification.
<b>Account Type</b>	The type of account associated with the payee. In this case, the account type will be 'Demand Draft'.
<b>Draft Type</b>	The type of draft associated with the Payee. The demand draft types can be: <ul style="list-style-type: none"> <li>• Domestic</li> <li>• International</li> </ul>
<b>Pay at City</b>	The name of the city in which the draft is payable.

Field Name	Description
<b>Pay at Country</b>	The country in which the draft is payable. This field appears only if the demand draft is an <b>International</b> demand draft.
<b>Delivery Location</b>	The delivery location i.e. the user's address or selected branch along with the address depending on what was defined at the time of payee creation or addition of new demand draft to the payee.
<b>Daily Limit</b>	The maximum limit that can be transferred to the payee via demand draft on a daily basis.
<b>Monthly Limit</b>	The maximum limit that can be transferred to the payee via demand draft on a monthly basis.

#### **Payee Account card Details (Peer to Peer)**

For information on viewing the details of a peer to peer payee, refer the User Manual *Oracle Banking Digital Experience Retail Peer to Peer Payment*.

#### **Payee Account card Details - SEPA (Credit Transfer and Card Payment)**

The following fields appear if the payee details being viewed are that of a SEPA fund transfer.

<b>Payee Name</b>	Name of the payee.
<b>Account Name</b>	Name of the payee as maintained in the bank account.
<b>Nickname</b>	The nickname assigned to the payee's account for easy identification.
<b>Account Type</b>	The type of account associated with the payee. In this case, the account type will be 'Domestic'.
<b>Pay Via</b>	
<b>Bank Details</b>	Details of the payee's bank account which will include the address and bank and branch codes.
<b>Daily Limit</b>	The maximum limit that can be transferred to this account on a daily basis.
<b>Monthly Limit</b>	The maximum limit that can be transferred to this account on a monthly basis.

#### **Payee Account card Details – UK Payments**

The following fields appear if the payee details being viewed are that of a UK payment.

<b>Payee Name</b>	Name of the payee.
<b>Account Name</b>	Name of the payee as maintained in the bank account.

Field Name	Description
<b>Nickname</b>	Name of the payee as maintained in the bank account.
<b>Account Type</b>	The type of account associated with the payee. In this case, the account type will be 'Domestic'.
<b>Pay Via</b>	The network through which funds will be transferred to the payee's bank account.
<b>Bank Details</b>	Details of the payee's bank account which will include the address and bank and branch codes.
<b>Daily Limit</b>	The maximum limit that can be transferred to this account on a daily basis.
<b>Monthly Limit</b>	The maximum limit that can be transferred to this account on a monthly basis.

3. Click **Pay** to transfer funds to the bank account or to issue demand draft depending on the account type maintained.

OR

Click the  icon (edit option) against the **Daily Limit** field to edit the daily transaction limit. The **Daily Limit** field appears in editable mode.

OR

Click the  icon (edit option) against the **Monthly Limit** field to edit the monthly transaction limit. The **Monthly Limit** field appears in editable mode.

OR

Click **Remove Limits** to delete the set limits assigned to the specific payee account. This option appears only if limits (either daily or monthly) are assigned to the account.



The **Remove Limits** pop-up appears.

Select the limit you wish to delete and click **OK**. A message stating that the selected limit has been removed successfully appears.

## 7.3 Edit Payee (Account Limits)

The user is provided with the facility to assign limits to each account of the payee. By way of assigning limits, the user is able to define the maximum daily and/or the maximum monthly limits that are to be applicable to an account of the payee. Alternately the user can also edit or remove these limits, once assigned.



### To edit payee account limits:

- From the **Payee List**, select and click on the expand option provided against the payee whose account limits you want to edit.  
OR  
Click  to search for a specific payee whose account limits you want to edit. A card displaying Payee Name, Payee Type and links to add a new account or new demand draft to the payee appears.
- Click  and then click the **View/Edit** option. The **View/ Edit Payee** screen appears.

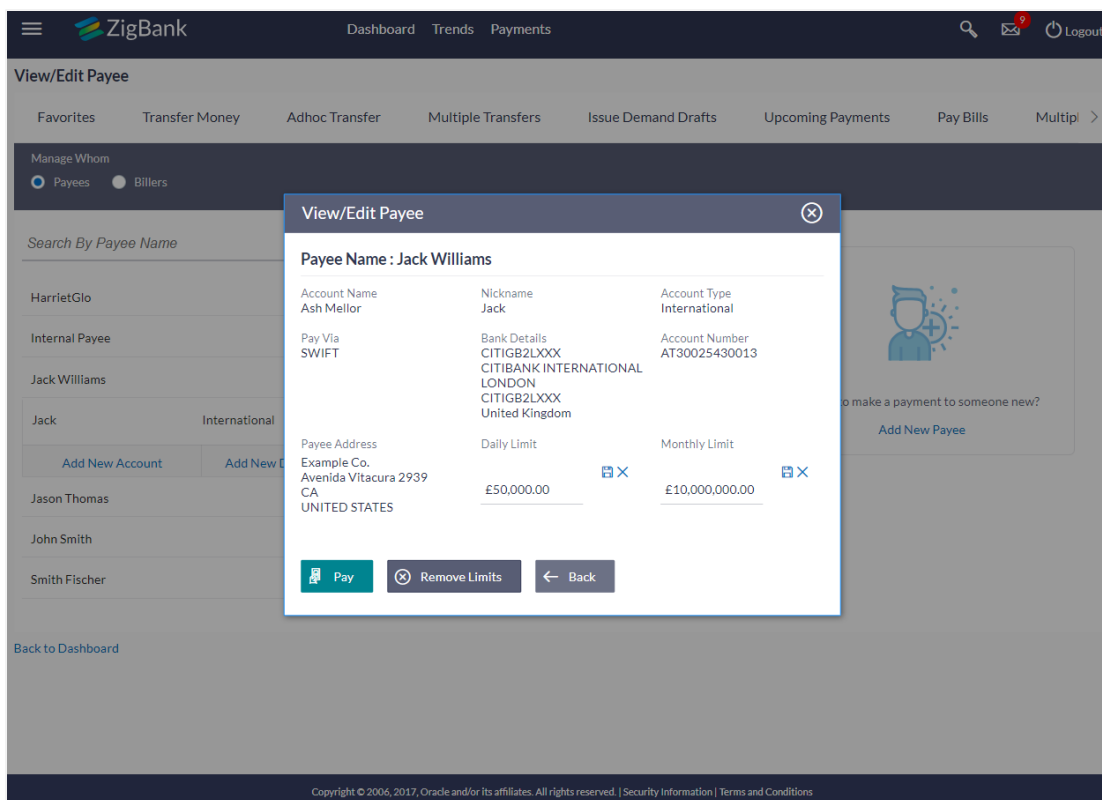
### View/ Edit Payee



The screenshot shows the ZigBank interface. At the top, there's a navigation bar with 'Dashboard', 'Trends', and 'Payments'. Below that, a 'View/Edit Payee' modal is open, displaying details for 'Jack Williams'. The modal includes a search bar, a list of payees, and a detailed view of the selected payee's account information and limits.

View/Edit Payee		
Payee Name: Jack Williams		
Account Name Ash Mellor	Nickname Jack	Account Type International
Pay Via SWIFT	Bank Details CITIGB2LXXX CITIBANK INTERNATIONAL LONDON CITIGB2LXXX United Kingdom	Account Number AT30025430013
Payee Address Example Co. Avenida Vitacura 2939 CA UNITED STATES	Daily Limit £50,000.00	Monthly Limit £10,000,000.00
 Pay	 Remove Limits	 Back

## Field Description

### Field Name Description

---

#### Payee Account Details - Bank Account

The following fields appear if the payee details being viewed are that of a bank account.

<b>Payee Name</b>	Name of the payee.
<b>Account Name</b>	Name of the payee as maintained in the bank account.
<b>Nickname</b>	The nickname assigned to the payee's account for easy identification.
<b>Account Type</b>	The type of account associated with the payee. The account types can be: <ul style="list-style-type: none"> <li>• Internal</li> <li>• Domestic</li> <li>• International</li> </ul>
<b>Pay Via</b>	The network through which funds will be transferred to the payee's bank account. This field appears if the Account Type is <b>Domestic</b> or <b>International</b> .
<b>Bank Details</b>	Details of the payee's bank account which will include the address and bank and branch codes. This field appears if the Account Type is <b>Domestic</b> or <b>International</b> .
<b>Account Number</b>	The bank account number of the payee.
<b>Payee Address</b>	Address of the payee in the bank account. This field appears if the Account Type is <b>International</b> .
<b>Daily Limit</b>	The maximum limit that can be transferred to this account on a daily basis.
<b>Monthly Limit</b>	The maximum limit that can be transferred to this account on a monthly basis.

#### Payee Account Details – Demand Draft

The following fields appear if the payee details being viewed are that of a demand draft.

<b>Payee Name</b>	Name of the payee.
<b>Nickname</b>	The nickname assigned to the payee's demand draft maintenance for easy identification.

---



---

**Field Name Description**

---

<b>Account Type</b>	The type of account associated with the payee. In this case, the account type will be 'Demand Draft'.
<b>Draft Type</b>	The type of draft associated with the Payee. The demand draft types can be: <ul style="list-style-type: none"> <li>• Domestic</li> <li>• International</li> </ul>
<b>Pay at City</b>	The name of the city in which the draft is payable.
<b>Pay at Country</b>	The country in which the draft is payable. This field appears only if the demand draft is an <b>International</b> demand draft.
<b>Delivery Location</b>	The delivery location i.e. the user's address or selected branch along with the address depending on what was defined at the time of payee creation or addition of new demand draft to the payee.
<b>Daily Limit</b>	The maximum limit that can be transferred to the payee via demand draft on a daily basis.
<b>Monthly Limit</b>	The maximum limit that can be transferred to the payee via demand draft on a monthly basis.

**Payee Account card Details (Peer to Peer)**

For information on editing a peer to peer payee maintenance, refer the User Manual **Oracle Banking Digital Experience Retail Peer to Peer Payment**.

**Payee Account Details - SEPA (Credit Transfer and Card Payment)**

The following fields appear if the payee details being viewed are that of a SEPA fund transfer.

<b>Payee Name</b>	Name of the payee.
<b>Account Name</b>	Name of the payee as maintained in the bank account.
<b>Account Number</b>	The bank account number of the payee.
<b>Nickname</b>	The nickname assigned to the payee's account for easy identification.
<b>Account Type</b>	The type of account associated with the payee. In this case, the account type will be 'Domestic'.

---

Field Name	Description
------------	-------------

<b>Pay Via</b>	The network through which funds will be transferred to the payee's bank account. In this case, the values can be either Credit Transfer or Card Payment.
----------------	--

<b>Bank Details</b>	Details of the payee's bank account which will include the address and bank and branch codes.
---------------------	---

<b>Daily Limit</b>	The maximum limit that can be transferred to this account on a daily basis.
--------------------	---

<b>Monthly Limit</b>	The maximum limit that can be transferred to this account on a monthly basis.
----------------------	---

### Payee Account card Details – UK Payments

The following fields appear if the payee details being viewed are that of a UK payment.

<b>Payee Name</b>	Name of the payee.
-------------------	--------------------

<b>Account Name</b>	Name of the payee as maintained in the bank account.
---------------------	--

<b>Account Number</b>	The bank account number of the payee.
-----------------------	---------------------------------------

<b>Account Nickname</b>	Name of the payee as maintained in the bank account.
-------------------------	--



<b>Account Type</b>	The type of account associated with the payee. In this case, the account type will be 'Domestic'.
---------------------	---

<b>Pay Via</b>	The network through which funds will be transferred to the payee's bank account.
----------------	--



<b>Bank Details</b>	Details of the payee's bank account which will include the address and bank and branch codes.
---------------------	---

<b>Daily Limit</b>	The maximum limit that can be transferred to this account on a daily basis.
--------------------	---

<b>Monthly Limit</b>	The maximum limit that can be transferred to this account on a monthly basis.
----------------------	---



- 
- Click the  icon (edit option) against the **Daily Limit** field to edit the daily transaction limit. The **Daily Limit** field appears in editable mode.  
OR  
Click the  icon (edit option) against the **Monthly Limit** field to edit the monthly transaction limit. The **Monthly Limit** field appears in editable mode.
  - Edit/enter limits against the daily/monthly limits field as the case may be.  
OR

Click **Remove Limits** to delete the set limits assigned to the specific payee account. This option appears only if limits (either daily or monthly) are assigned to the account. The **Remove Limits** pop-up appears. Select the limit you wish to delete and click **OK**. A message stating that the selected limit has been removed successfully appears.

5. Click  against the Daily Limit / Monthly Limit field to save the changes made. A message stating that the limits have been set appears.  
OR  
Click  to cancel the editing.  
OR  
Click **Pay** to transfer funds/ issue demand draft.  
OR  
Click **Remove Limits** to delete the set limits. This option appears only if limits (either daily or monthly) are assigned to the account.  
The **Remove Limits** pop-up appears. Select the limit you wish to delete and click **OK**. A message stating that the selected limit has been removed successfully appears.

## 7.4 Delete Payee Account/Demand Draft

**To delete a payee account or demand draft:**

1. From the **Payee List**, select and click on the expand option provided against the payee whose account you want to delete.  
OR  
Click  to search for a specific payee whose account you want to delete. A card displaying Payee Name, Payee Type and links to add a new account or new demand draft to the payee appears.
2. Click  and then click **Delete**. The **Delete Payee** pop up window appears with a warning message prompting the user to confirm the deletion.

## Delete Payee

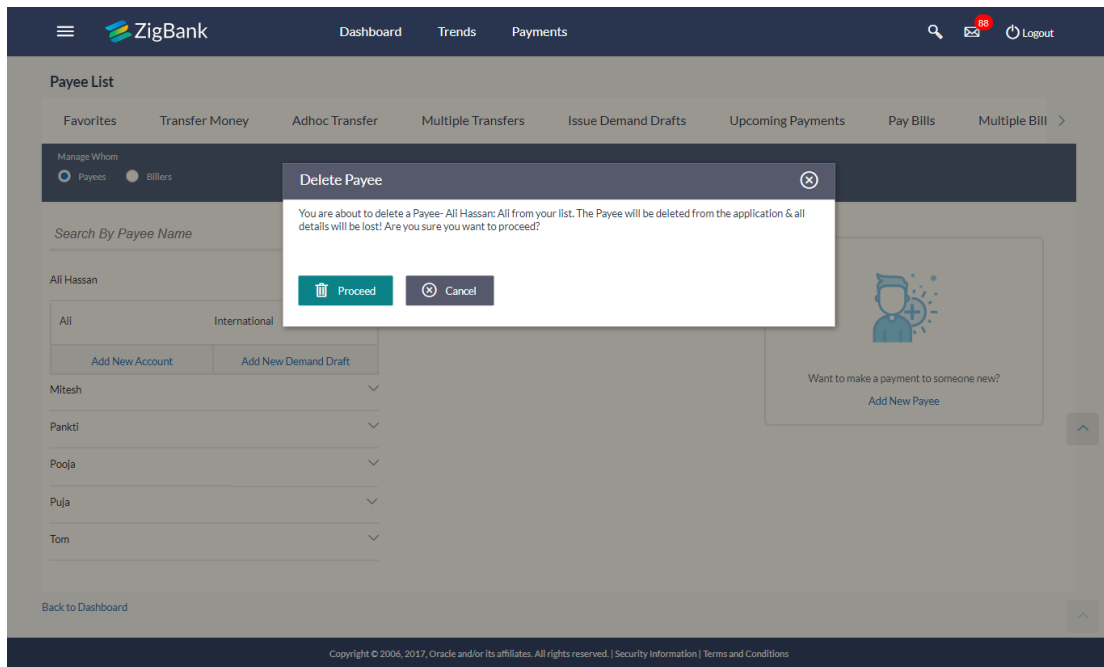

3. Click **Proceed** to proceed with the deletion request.  
OR  
Click **Cancel** to cancel the deletion process.
4. The screen confirming payee deletion appears. The details of the account/draft deleted are also displayed on this screen.  
Click **Go to Dashboard** to navigate to the dashboard.  
OR  
Click **More Payment Options** to access other payment options.

## 7.5 Add New Payee

To add a new payee:

1. In the **Manage Payee** screen, click the **Add New Payee** link.  
The **Add New Payee** pop up window appears with the options to choose the type of account that is to be assigned to the payee being created.
2. Select the option **Bank Account** to add a payee having a bank account. For more information on **Add Payee - Bank Account**, refer the *Payee Maintenance - Bank Account* section.  
OR
3. Select the option Demand Draft to add details of a demand draft to be issued to a payee. For more information on **Add Payee - Demand Draft**, refer the *Payee Maintenance – Demand Draft* section.

### FAQs

1. **Can I delete payees towards whom I no longer need to make payments?**

You can delete individual accounts or demand drafts of a payee towards whom you no longer wish to make payments. If the payee has a single account or demand draft assigned, the payee record is also deleted. However, if the payee whose account or demand draft details you delete also has other accounts or demand drafts assigned, these accounts or demand draft details will not be impacted by the deletion of any other account or demand draft.

2. **Can I edit the payee name or account details of the payee once a payee has been created?**

No. You can only edit or remove the limits i.e. the daily or monthly limits assigned to the account or demand draft of the payee.

[Home](#)

## 8. Add Payee – Bank Account

While adding a payee, the user is provided with the option to either assign an account number to the payee or to define a demand draft template to be used while issuing demand drafts towards the payee.

This section documents the addition of a payee with transfer type as bank account.

The Account types supported are as follows:

- Internal
- Domestic
- International

### How to reach here:

*Dashboard > Payments Widget > Manage Payees & Billers > Add New Payee > Bank Account*  
OR

*Dashboard > Toggle Menu > Payments > Manage Payees & Billers > Add New Payee > Bank Account*  
OR

*Dashboard > Payments Menu > Transfer Money > Manage Payees & Billers > Add New Payee > Bank Account*

### To add a new payee:

1. Click the **Add New Payee** link on the **Manage Payees** screen. The pop up screen on which to specify the transfer type i.e. bank account or demand draft, appears.
2. Select the **Bank Account** option and click **Ok**, to create bank account type of payee. The **Add Payee** screen appears.

## Add New Payee popup screen

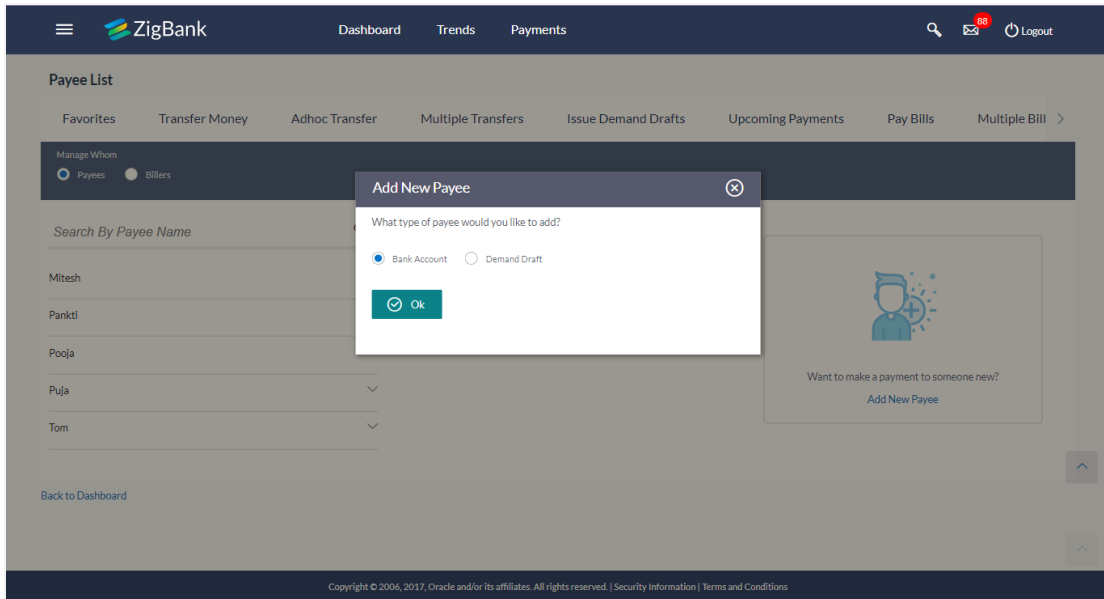

## Field Description

### Field Name

### Description

**What type of payee would you like to add?**

The transfer type of the new payee.  
The types can be:

- Bank Account
- Demand Draft

## 8.1 Add Payee – Internal Bank Account

While creating a payee that has an internal bank account, i.e. an account that is held in the same bank as that of the user's, in addition to the basic payee information that needs to be captured, the account number and branch in which the payee's account is held will also need to be identified.

**To add a payee with an internal account:**

1. In the **Account Type** field, select the **Internal** option as type of account associated with the payee.

### Add Payee – Internal Account

The screenshot shows the 'Add Payee' form in the ZigBank interface. The form is titled 'Add Payee' and has two tabs: 'Bank Account' (selected) and 'Demand Draft'. The 'Payee Name' field contains 'Sara J'. The 'Account Type' field has three radio buttons: 'Internal' (selected), 'Domestic', and 'International'. The 'Account Number' field contains 'AT30009610028'. The 'Account Name' field contains 'Sara J'. The 'Nickname' field contains 'Sara'. At the bottom of the form, there are two buttons: 'Add' (with a plus icon) and 'Cancel' (with a minus icon). A 'Back to Dashboard' link is located at the bottom left. On the right side, there is a sidebar with a message: 'Transfer money faster than ever! Transferring money towards payees is easy and quick. Perform a one-time Payee addition maintenance and simply select the payee while transferring funds. The payee details will be listed on the screen for verification and all you have to do is enter the amount and date of transfer to initiate the transfer.'

### Field Description

Field Name	Description
------------	-------------

<b>Payee Name</b>	Specify the name by which the payee is to be identified.
-------------------	--

<b>Account Type</b>	Select the type of account associated with the payee.
---------------------	---

The options are:

- Internal
- Domestic
- International

<b>Account Number</b>	Specify the account number of the payee.
-----------------------	--



Field Name	Description
<b>Account Name</b>	Enter the name of the payee as maintained against the payee's bank account.
<b>Nickname</b>	Specify a nickname to be assigned to the specific account of the payee for the purpose of easy identification.

2. In the **Payee Name** field, enter the name of the payee.
3. In the **Account Number** field, enter the payee's account number.
4. In the **Account Name** field, enter the payee's names as maintained against the payee's account.
5. In the **Nickname** field, enter a nickname to be assigned to the specific account of the payee.
6. Click **Add** to add a payee.  
OR  
Click **Cancel** to cancel the transaction.  
OR  
Click the **Back to Dashboard** link, to navigate to the dashboard.
7. The **Add Payee - Review** screen appears. Verify the details, and click **Confirm**.  
OR  
Click **Back** to navigate back to the previous screen.  
OR  
Click **Cancel** to cancel the transaction and to navigate back to 'Dashboard'.
8. The success message appears along with the account details.  
Click **Go to Dashboard**, to navigate to the dashboard.  
OR  
Click **More Payment Options** to access other payment options.  
OR  
Click **Pay Now** to initiate a fund transfer towards the added payee.  
OR  
Click **Setup Payee Limits** to assign limits (daily and/or monthly) to the payee's account.

## 8.2 Add Payee – Domestic Bank Account

A domestic account transfer is one which involves the transfer of funds to an account that is held with another bank within the same country. Hence, while adding a payee that has a domestic bank account, details of the payment network, through which funds are to be transferred, along with the bank and branch in which the payee's account is held will also need to be captured in addition to the payee details and account specific information.

### 8.2.1 Domestic Account – India

The following steps are applicable for domestic account payee creation if the geographical region configured is India.

#### To add a payee for domestic account transfer:

1. In the **Account Type** field, select the option **Domestic** to indicate the type of account associated with the payee.

## Add Payee – Domestic Account

The screenshot shows the 'Add Payee' form in the ZigBank interface. The form is titled 'Add Payee' and has two tabs: 'Bank Account' (selected) and 'Demand Draft'. The form fields are as follows:

- Payee Name:** Sara Abraham
- Account Type:** Internal, **Domestic** (selected), International
- Account Number:** AT30025430013
- Account Name:** Sara Abraham
- Pay Via:**  NEFT,  RTGS,  IMPS
- IFSC Code:** HDFC0000017  
HDFC Bank Ltd  
361, Saks Avenue  
Chennai  
HDFC0000017  
[Reset](#)
- Nickname:** Sara

At the bottom of the form, there are 'Add' and 'Cancel' buttons. A 'Back to Dashboard' link is also present. On the right side of the form, there is a promotional message:

**Transfer money faster than ever!**  
Transferring money towards payees is easy and quick.  
Perform a one-time Payee addition maintenance and simply select the payee while transferring funds.  
The payee details will be listed on the screen for verification and all you have to do is enter the amount and date of transfer to initiate the transfer.

Copyright © 2006, 2017, Oracle and/or its affiliates. All rights reserved. | [Security Information](#) | [Terms and Conditions](#)

### Field Description

Field Name	Description
------------	-------------

<b>Payee Name</b>	Specify the name by which the payee is to be identified.
-------------------	--

<b>Account Type</b>	Select the type of account associated with the payee. The options are:
---------------------	---

- Internal
- Domestic
- International

<b>Account Number</b>	Specify the account number of the payee.
-----------------------	--

<b>Account Name</b>	Enter the name of the payee as maintained against the payee's bank account.
---------------------	---

Field Name	Description
------------	-------------

<b>Pay Via</b>	Select the network through which transfers are to be made. The following options appear as per India region configuration: <ul style="list-style-type: none"> <li>• NEFT</li> <li>• RTGS</li> <li>• IMPS</li> </ul>
----------------	--

<b>IFSC /Bank Code</b>	Specify the IFSC /Bank Code of the payee's account.
------------------------	---

#### IFSC /Bank Code Look up

The following fields are displayed on a pop up window if the Lookup IFSC Code link is selected.

<b>IFSC Code</b>	The facility to lookup bank details based on the IFSC Code.
------------------	---

<b>Bank Name</b>	The facility to lookup the bank details based on bank name.
------------------	---

<b>State</b>	The facility to lookup bank details by combining search through IFSC Code and Bank Name along with the state in which the payee's account is held.
--------------	--

<b>City</b>	The facility to lookup bank details by combining search through IFSC Code and Bank Name along the city in which the payee's account is held.
-------------	--

#### IFSC Code Lookup - Search Result

The following details are displayed per record as search results arrived at based on the information defined in the search fields.

<b>Bank Name</b>	Name of the bank.
------------------	-------------------

<b>Branch</b>	Bank branch name.
---------------	-------------------

<b>Address</b>	The complete address of the bank.
----------------	-----------------------------------

<b>IFSC Code</b>	The IFSC code value. This value will be displayed as a link which will be selectable. On selecting the link, the IFSC code and bank details are populated on the Add Payee – Domestic Account screen.
------------------	---

<b>Bank Details</b>	The details of the bank that include the IFSC Code as well as the name and address of the bank and branch in which the payees account is held.
---------------------	--

<b>Nickname</b>	Specify a nickname to be assigned to the specific account of the payee for the purpose of easy identification.
-----------------	--

2. In the **Payee Name** field, enter the name of the payee for identification.
3. In the **Account Number** field, enter the payee's account number.

4. In the **Account Name** field, enter the payee name.
5. In the **Pay Via** field, select the specific network for payment.
6. In the **IFSC Code** field, enter the IFSC /Bank Code or select it from the lookup.
7. If you search the IFSC code by clicking the **Lookup IFSC Code** link.
  - In the **IFSC Code** and **Bank Name** field, enter the IFSC code and bank name of the beneficiary bank.
  - Specify either the name of the city or the state in which the payee's account is held in the fields **City** or **State**.
  - Click **Search**. The bank details appear.
  - Click the **IFSC Code** link from the search results. The bank details get populated on the **Add Payee – Domestic Account** screen.
  - OR
  - Enter the IFSC /Bank Code, click **Verify** to fetch bank details based on **Bank Code** (BIC).
  - OR
  - Click **Reset** to clear the populated data and enter/ select a new IFSC Code.
8. In the **Nickname** field, enter a nickname to be assigned to the specific account of the payee.
9. Click **Add** to add a payee.
  - OR
  - Click **Cancel** to cancel the transaction.
  - OR
  - Click the **Back to Dashboard** link, to navigate to the dashboard.
10. The **Add Payee - Review** screen appears. Verify the details, and click **Confirm**.
  - OR
  - Click **Back** to navigate back to the previous screen.
  - OR
  - Click **Cancel** to cancel the transaction and to navigate back to 'Dashboard'.
11. The success message appears along with the account details.
  - Click **Go to Dashboard**, to navigate to the dashboard.
  - OR
  - Click **More Payment Options** to access other payment options.
  - OR
  - Click **Pay Now** to initiate a fund transfer towards the added payee.
  - OR
  - Click **Setup Payee Limits** to assign limits (daily and/or monthly) to the payee's account.

### 8.2.2 Domestic Account – UK

The following steps are applicable for domestic account payee creation if the geographical region configured is the UK.

To add a payee for domestic account transfer:

1. In the **Account Type** field, select the option **Domestic** option as type of account associated with the payee.

## Add Payee – UK Bank Account – Non Urgent

 Dashboard Trends Payments 73 Logout

### Add Payee

**Bank Account** Demand Draft

Payee Name  
John Miller

Account Type  
 Internal  Domestic  International

Payment Type  
 Non-urgent  Urgent  Faster

Account Number  
AT30025430013

Account Name  
John Miller

Sort Code  
HDFC0000017  
HDFC Bank Ltd  
361, Saks Avenue  
Chennai

Nickname

[Back to Dashboard](#)



**Transfer money faster than ever!**

Transferring money towards payees is easy and quick.

Perform a one-time Payee addition maintenance and simply select the payee while transferring funds.

The payee details will be listed on the screen for verification and all you have to do is enter the amount and date of transfer to initiate the transfer.

Copyright ZigBank Ltd. All Rights Reserved | Security Information | Terms and Conditions

## Add Payee – UK Bank Account – Urgent

 [Dashboard](#) [Trends](#) [Payments](#) [Logout](#)

### Add Payee

[Bank Account](#) [Demand Draft](#)

Payee Name  
John Miller

Account Type

Payment Type

Account Number  
AT30009610028

Account Name  
John Miller

SWIFT Code  
HDFC0000017

[Lookup Swift Code](#)

Nickname  
John

[Back to Dashboard](#)

**Transfer money faster than ever!**

Transferring money towards payees is easy and quick.

Perform a one-time Payee addition maintenance and simply select the payee while transferring funds.

The payee details will be listed on the screen for verification and all you have to do is enter the amount and date of transfer to initiate the transfer.

Copyright ZigBank Ltd. All Rights Reserved | [Security Information](#) | [Terms and Conditions](#)

## Add Payee – UK Bank Account – Faster

**Add Payee**

Bank Account Demand Draft

Payee Name  
John Miller

Account Type  
Internal Domestic International

Payment Type  
Non-urgent Urgent Faster

Account Number  
AT30025430013

Account Name  
John Miller

Sort Code  
HDFC0000017  
HDFC Bank Ltd  
361, Saks Avenue  
Chennai  
Reset

Nickname  
John

Back to Dashboard

Copyright ZigBank Ltd. All Rights Reserved | Security Information | Terms and Conditions

**Transfer money faster than ever!**

Transferring money towards payees is easy and quick.

Perform a one-time Payee addition maintenance and simply select the payee while transferring funds.

The payee details will be listed on the screen for verification and all you have to do is enter the amount and date of transfer to initiate the transfer.

### Field Description

Field Name	Description
<b>Payee Name</b>	Specify the name by which the payee is to be identified.
<b>Account Type</b>	Select the type of account associated with the payee. The options are: <ul style="list-style-type: none"> <li>Internal</li> <li>Domestic</li> <li>International</li> </ul>

## Field Description

### Field Name Description

---

**Payment Type** Select the type of UK payment

The options are:

- Urgent (Requires SWIFT code)
- Non-Urgent (Requires Sort code)
- Faster (Requires Sort code)

**Account Number** Specify the account number of the payee.

**Account Name** Enter the name of the payee as maintained against the payee's bank account.

### UK Payment - Non-Urgent and Faster payment

The following fields are applicable if either of the two options, **Non-Urgent** or **Faster** are selected as Payment Type.

**Sort Code** Specify the Sort code associated with the payee's account.

### Sort Code Lookup

The following fields are displayed on a pop up window if the **Lookup Sort Code** link is selected.

**Bank Name** The facility to lookup the bank details based on bank name.

**City** The facility to lookup bank details based on name of the city in which the payee's account is held.

### Sort Code Lookup - Search Result

The following details are displayed per record as search results arrived at based on the information defined in the search fields.

**Bank Name** Name of the bank.

**Branch** Bank branch name.

**Address** The complete address of the bank.

**Sort Code** The Sort Code value. This value will be displayed as a link which will be selectable. On selecting the link, the Sort code and bank details are populated on the Add Payee – Domestic Account screen.

**Bank Details** The details of the bank that include the Sort Code as well as the name and the address of the bank and branch in which the payee's account is held.

---



Field Name	Description
------------	-------------

### UK Payment - Urgent

The following fields are applicable if the option **Urgent** is selected as Payment Type.

**SWIFT Code** Specify the SWIFT code associated with the payee's account.

### SWIFT Code Lookup

The following fields are displayed on a pop up window if the **Lookup SWIFT Code** link is selected.

**SWIFT Code** The facility to lookup bank details based on the SWIFT Code.

**Bank Name** The facility to lookup the bank details based on bank name.

**Country** The facility to lookup bank details by combining search through SWIFT Code and Bank Name along with the country in which the payee's account is held.

**City** The facility to lookup bank details by combining search through SWIFT Code and Bank Name along the city in which the payee's account is held.

### SWIFT Code Lookup - Search Result

The following details are displayed per record as search results arrived at based on the information defined in the search fields.

**Bank Name** Name of the bank.

**Address** The complete address of the bank.

**SWIFT Code** The SWIFT code value. This value will be displayed as a link which will be selectable. On selecting the link, the SWIFT code and bank details are populated on the Add Payee – Domestic Account screen.

**Nickname** Specify a nickname to be assigned to the specific account of the payee for the purpose of easy identification.

- 
2. In the **Payee Name** field, enter the name of the payee for identification.
  3. In the **Payment Type** field, select the specific network for payment.
    - a. If you select either the **Non-Urgent** or **Faster** payment option:
      - i. In the **Account Number** field, enter the payee's account number.
      - ii. In the Account Name field, enter the payee name.
      - iii. In the **Sort Code** field, enter the Sort Code or select it from the lookup.  
OR  
Click **Reset** to clear the populated data and enter/ select a new Sort Code.
      - iv. Click **Verify** to fetch bank details based on the Sort Code.
    - b. If you select **Urgent** payment option:

- i. In the **Account Number** field, enter the payee's account number.
  - ii. In the **Account Name** field, enter the payee name.
  - iii. In the **Swift Code** field, enter the Swift Code or select it from the lookup.  
OR  
Click **Reset** to clear the populated data and enter/ select a new SWIFT Code.
  - iv. Click **Verify** to fetch bank details based on the SWIFT Code.
4. In the **Nickname** field, enter a nickname to be assigned to the specific account of the payee.
5. Click **Add** to add a payee.  
OR  
Click **Cancel** to cancel the transaction.  
OR  
Click the **Back to Dashboard** link, to navigate to the dashboard.
6. The **Add Payee - Review** screen appears. Verify the details, and click **Confirm**.  
OR  
Click **Back** to navigate back to the previous screen.  
OR  
Click **Cancel** to cancel the transaction and to navigate back to 'Dashboard'.
7. The success message appears along with the account details.  
Click **Go to Dashboard**, to navigate to the dashboard.  
OR  
Click **More Payment Options** to access other payment options.  
OR  
Click **Pay Now** to initiate a fund transfer towards the added payee.  
OR  
Click **Setup Payee Limits** to assign limits (daily and/or monthly) to the payee's account.

### 8.2.3 Domestic Account – SEPA Payment

The following steps are applicable for domestic account payee creation if the geographical region configured is any of the member states that comprises the European Union.

#### To add a payee for domestic account transfer:

1. In the **Account Type** field, select the option **Domestic** to indicate the type of account associated with the payee.

#### Add Payee – SEPA Payment – Card

The screenshot shows the 'Add Payee' form in the ZigBank interface. The form is titled 'Add Payee' and has two tabs: 'Bank Account' (selected) and 'Demand Draft'. The form contains the following fields and options:

- Payee Name:** Samuel Colt
- Account Type:** Internal, **Domestic** (selected), International
- Payment Type:**  Card,  Credit
- Account Number:** AT30009610028
- Account Name:** Samuel Colt
- Bank Code (BIC):** HDFC0000017, HDFC Bank Ltd, 361, Saks Avenue, Chennai. A 'Reset' button is located below this field.
- Nickname:** Sam

At the bottom of the form, there are 'Add' and 'Cancel' buttons. A 'Back to Dashboard' link is also present. On the right side of the form, there is a promotional message:

**Transfer money faster than ever!**

Transferring money towards payees is easy and quick.

Perform a one-time Payee addition maintenance and simply select the payee while transferring funds.

The payee details will be listed on the screen for verification and all you have to do is enter the amount and date of transfer to initiate the transfer.

The footer of the page contains the copyright information: Copyright © 2006, 2017, Oracle and/or its affiliates. All rights reserved. | Security Information | Terms and Conditions

## Add Payee – SEPA Payment – Credit

The screenshot shows the 'Add Payee' interface in the ZigBank system. The page title is 'Add Payee' and the sub-section is 'Bank Account'. The form contains the following fields and options:

- Payee Name:** Samuel Colt
- Account Type:** Internal, Domestic (selected), International
- Payment Type:** Card, Credit (selected)
- Account Number:** AT30009610028
- Account Name:** Samuel Colt
- Bank Code (BIC):** HDFC0000017, HDFC Bank Ltd, 361, Saks Avenue, Chennai
- Nickname:** Sam

At the bottom of the form, there are 'Add' and 'Cancel' buttons. A 'Back to Dashboard' link is also present. On the right side, a message box states: 'Transfer money faster than ever! Transferring money towards payees is easy and quick. Perform a one-time Payee addition maintenance and simply select the payee while transferring funds. The payee details will be listed on the screen for verification and all you have to do is enter the amount and date of transfer to initiate the transfer.'

### Field Description

Field Name	Description
------------	-------------

<b>Payee Name</b>	Specify the name by which the payee is to be identified.
-------------------	--

<b>Account Type</b>	Select the type of account associated with the payee. The options are:
---------------------	---

- Internal
- Domestic
- International

<b>Payment Type</b>	Select the type of SEPA payment applicable to the payee. The options are:
---------------------	--

- Card Payment
- Credit Transfer

Field Name	Description
<b>Account Number (IBAN)</b>	Specify the international bank account number of the Payee.
<b>Account Name</b>	Enter the name of the payee as maintained against the payee's bank account.
<b>Bank Code (BIC)</b>	Enter the international bank code of the bank in which the payee's account is held.

#### Look up Bank (BIC) Code

The following fields are displayed on a pop up window if the Look up Bank (BIC) Code link is selected.

<b>Look up Bank (BIC) Code</b>	The facility to lookup bank details based on the BIC Code.
<b>Bank Name</b>	The facility to lookup the bank details based on bank name.
<b>City</b>	The facility to lookup bank details by combining search through Bank (BIC) Code and Bank Name along the city in which the payee's account is held.

#### Bank (BIC) Code Lookup - Search Result

The following details are displayed per record as search results arrived at based on the information defined in the search fields.

<b>Bank Name</b>	Name of the bank.
<b>Address</b>	The complete address of the bank.
<b>(BIC) Code</b>	The (BIC) Code value. This value will be displayed as a link which will be selectable. On selecting the link, the IFSC code and bank details are populated on the Add Payee – Domestic Account screen.
<b>Nickname</b>	Specify a nickname to be assigned to the specific account of the payee for the purpose of easy identification.

2. In the **Payee Name** field, enter the name of the payee for identification.
3. In the **Payment Type** field, select the specific network for payment.
4. In the **Account Number** field, enter the payee's account number.
5. In the **Account Name** field, enter the payee name.
6. In the Bank Code (BIC) field, enter the international Bank code of the bank in which the payee's account is held.  
OR  
Click Reset to clear the data and enter/ select a new Bank Code (BIC).
7. Click Verify to fetch bank details.

8. In the **Nickname** field, enter a nickname to be assigned to the specific account of the payee.
9. Click **Add** to add a payee.  
OR  
Click **Cancel** to cancel the transaction.  
OR  
Click the **Back to Dashboard** link, to navigate to the dashboard.
10. The **Add Payee - Review** screen appears. Verify the details, and click **Confirm**.  
OR  
Click **Back** to navigate back to the previous screen.  
OR  
Click **Cancel** to cancel the transaction and to navigate back to 'Dashboard'.
11. The success message appears along with the account details.  
Click **Go to Dashboard**, to navigate to the dashboard.  
OR  
Click **More Payment Options** to access other payment options.  
OR  
Click **Pay Now** to initiate a fund transfer towards the added payee.  
OR  
Click **Setup Payee Limits** to assign limits (daily and/or monthly) to the payee's account.

## 8.3 Add Payee – International Bank Account

An international fund transfer involves the transfer of funds to an account that is maintained outside the country and beyond geographical boundaries. Hence, while adding a payee who holds an international account, the user is required to specify extensive details of the payee's account including the network code to be used to transfer money to the account as well as the details of the bank in which the account is held.

### To add a payee with an international account:

1. In the **Account Type** field, select the **International** option as type of account associated with the payee.

### Add Payee - International Account

The screenshot shows the 'Add Payee' interface in the ZigBank application. The page title is 'Add Payee' and there are two tabs: 'Bank Account' (selected) and 'Demand Draft'. The form contains the following fields and options:

- Payee Name:** Jack Williams
- Account Type:** Radio buttons for Internal, Domestic, and International. 'International' is selected.
- Account Number:** AT30025430013
- Account Name:** Ash Mellor
- Address Line 1:** Example Co.
- Address Line 2:** Avenida Vitacura 2939
- City:** CA
- Country:** UNITED STATES (dropdown menu)
- Pay Via:** Radio buttons for SWIFT Code (selected), NCC, and Bank Details.
- SWIFT Code:** CITIB2LXXX CITIBANK INTERNATIONAL LONDON CITIB2LXXX GB
- Reset:** A button to clear the SWIFT code field.
- Nickname:** Jack
- Buttons:** '+ Add' and 'Cancel' buttons at the bottom of the form.

On the right side of the form, there is a callout box with the following text:

**Transfer money faster than ever!**

Transferring money towards payees is easy and quick.

Perform a one-time Payee addition maintenance and simply select the payee while transferring funds.

The payee details will be listed on the screen for verification and all you have to do is enter the amount and date of transfer to initiate the transfer.

At the bottom of the page, there is a 'Back to Dashboard' link and a copyright notice: 'Copyright © 2006, 2017, Oracle and/or its affiliates. All rights reserved. | Security Information | Terms and Conditions'.

**Field Description**

<b>Field Name</b>	<b>Description</b>
<b>Payee Name</b>	Specify the name by which the payee is to be identified.
<b>Account Type</b>	Select the type of account associated with the payee. The options are: <ul style="list-style-type: none"> <li>• Internal</li> <li>• Domestic</li> <li>• International</li> </ul>
<b>Account Number</b>	Specify the account number of the payee.
<b>Account Name</b>	Enter the name of the payee as maintained against the payee's bank account.
<b>Address Line 1- 2</b>	Address of the payee.
<b>City</b>	City of the payee.
<b>Country</b>	Country of the payee.
<b>Pay Via</b>	Select the network through which the transfer is to take place. The options are: <ul style="list-style-type: none"> <li>• Swift Code</li> <li>• NCC (National Clearing code)</li> <li>• Bank Details</li> </ul>
<b>SWIFT / National clearing code value</b>	The SWIFT code will need to be identified if <b>SWIFT Code</b> has been selected in the <b>Pay Via</b> field.
<b>Lookup Swift Code</b>	Link to search the SWIFT code.
<b>SWIFT code Look up</b>	
The following fields appear on a pop up window if the <b>Lookup SWIFT Code</b> link is selected.	
<b>SWIFT Code</b>	The facility to lookup bank details based on SWIFT code.
<b>Bank Name</b>	The facility to search for the SWIFT code based on the bank name.
<b>Country</b>	The facility to search for the SWIFT code based on the country.
<b>City</b>	The facility to search for the SWIFT code based on city.
<b>SWIFT Code Lookup - Search Result</b>	



Field Name	Description
<b>SWIFT Code</b>	SWIFT code value.
<b>Bank Name</b>	Name of the bank.
<b>Address</b>	Displays complete address of the bank.

#### National clearing code Look up

The following fields appear on a pop up window if the **Lookup National Clearing Code** link is selected.

<b>NCC Type</b>	The facility to search for the national clearing code by type.
<b>NCC Code</b>	The facility to search for bank details by defining the national clearing code.
<b>Bank Name</b>	The facility to search for the national clearing code by defining the name of the bank.
<b>City</b>	The facility to search for the national clearing code by city.

#### NCC Lookup - Search Result

<b>Bank Name</b>	Name of the bank.
<b>Branch</b>	Bank branch name.
<b>Address</b>	Displays complete address of the bank.
<b>NCC Code</b>	NCC code of the bank branch.

Below fields appears if the **Bank Details** option is selected in **Pay Via** field.

<b>Bank Name</b>	Name of the bank in which the payee account is held.
<b>Bank address</b>	Complete address of the bank at which the payee account is held.
<b>Country</b>	Country of the bank.
<b>City</b>	City to which the bank belongs.
<b>Nickname</b>	Specify a nickname to be assigned to the specific account of the payee for the purpose of easy identification.

2. In the **Payee Name** field, enter the name of the payee for identification.
3. In the **Account Number** field, enter the payee's account number.
4. In the **Account Name** field, enter the payee name.
5. In the **Pay Via** field, select the appropriate network for payment.

- a. If you select **Swift** option:
  - i. In the **SWIFT code** field, enter the SWIFT code or select it from the lookup.  
OR  
Click **Reset** to clear the populated data and enter/ select a new SWIFT Code.
  - ii. Click **Verify** to fetch bank details based on Bank Code (BIC).
- b. If you select **NCC** option:
  - i. In the **National Clearing code** field, enter the National Clearing code or select it from the lookup.
  - ii. Click **Verify** to fetch bank details based on Bank Code (BIC).
- c. If you select **Bank details** option:
  - i. In the **Bank Name** field, enter the bank name.
  - ii. In the **Bank Address** field, enter the complete address of the bank.
  - iii. From the **Country** list, select the country of the bank.
  - iv. From the **City** list, select the city to which the bank belongs.
6. In the **Nickname** field, enter a nickname to be assigned to the specific account of the payee.
7. Click **Add** to add a payee.  
OR  
Click **Cancel** to cancel the transaction.  
OR  
Click the **Back to Dashboard** link, to navigate to the dashboard.
8. The **Add Payee - Review** screen appears. Verify the details, and click **Confirm**.  
OR  
Click **Back** to navigate back to the previous screen.  
OR  
Click **Cancel** to cancel the transaction and to navigate back to 'Dashboard'.
9. The success message appears along with the account details.  
Click **Go to Dashboard**, to navigate to the dashboard.  
OR  
Click **More Payment Options** to access other payment options.  
OR  
Click **Pay Now** to initiate a fund transfer towards the added payee.  
OR  
Click **Setup Payee Limits** to assign limits (daily and/or monthly) to the payee's account.

[Home](#)

## 9. Add Payee – Demand Draft

A Demand Draft is a pre-paid negotiable instrument. The issuing bank undertakes to make payment in full when the instrument is presented by the payee. The demand draft is made payable at a specified centre and can be issued in local currency as well as in (allowed) foreign currencies. A foreign currency demand draft can be requested using International Demand Draft while a pay order or local currency demand draft can be requested using the Domestic Demand Draft transaction. A Demand Draft, as compared to a cheque is issued by the Bank against the Bank's own funds and hence there is a reduced risk of the cheque not clearing. Users are able to save the payee details of the draft through payee maintenance. Beneficiary for demand drafts are of two types:

- Domestic Demand Draft
- International Demand Draft

The application also provides an additional option to have the demand draft delivered at the customer's convenience. Two options are provided for the same:

- My address – Deliver either the demand draft to customer's communication address.
- Branch Near Me – Deliver the demand draft to any branch near to the user.

### How to reach here:

*Dashboard > Payments Widget > Manage Payees & Billers > Add New Payee > Demand Draft > Add Payee*

OR

*Dashboard > Toggle Menu > Payments > Manage Payees & Billers > Add New Payee > Demand Draft > Add Payee*

OR

*Dashboard > Payments Menu > Manage Payees & Billers > Add New Payee > Demand Draft > Add Payee*

### To add a new demand draft payee:

1. Click the **Add New Payee** link on the Manage Payees screen. The pop up screen on which to specify the transfer type i.e. bank account or demand draft, appears.
2. Select the **Demand Draft** option and click **Ok**, to create a demand draft type of payee. The **Add Payee** screen appears.

## Add New Payee popup screen

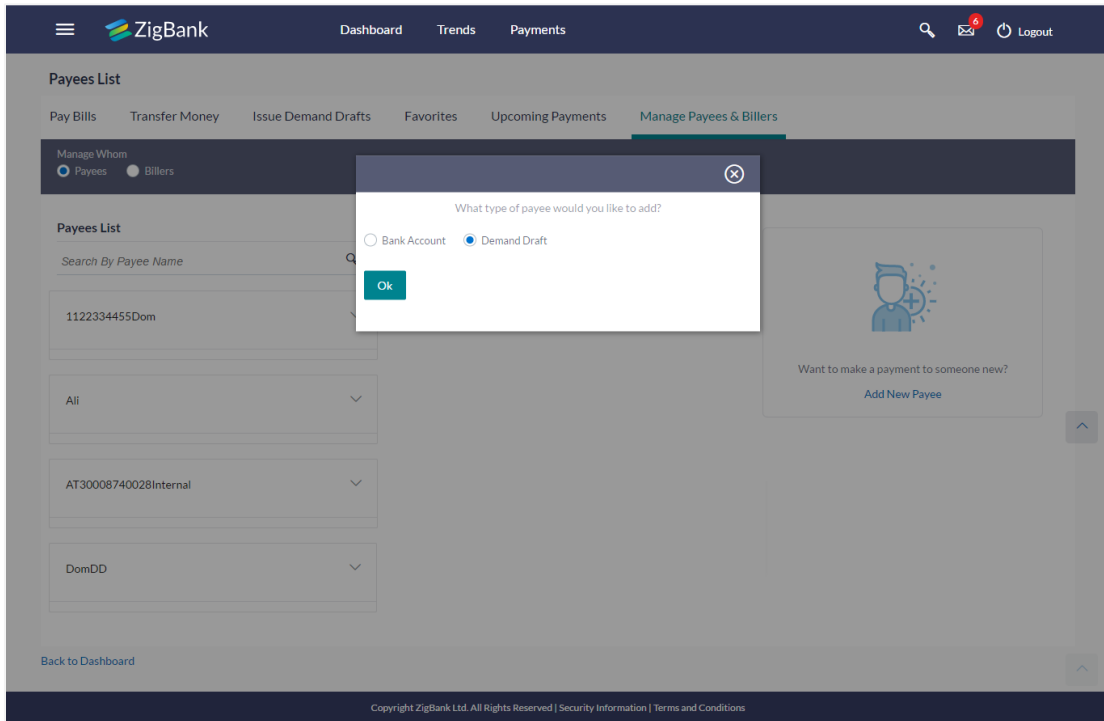

## Field Description

### Field Name

### Description

**What type of payee would you like to add?**

The transfer type of the new payee.

The type can be:

- Bank Account
- Demand Draft

## 9.1 Add Payee – Domestic Demand Draft

A Domestic Draft payee is created to initiate a request to issue a draft which is payable at a location within the country. The user provides the payee details, the details of draft to be issued in favour of and the payable location.

**To create a domestic demand draft payee:**

### Add Payee - Domestic Demand Draft

The screenshot shows the 'Add Payee' form in the ZigBank application. The form is titled 'Add Payee' and has two tabs: 'Bank Account' and 'Demand Draft'. The 'Demand Draft' tab is active. The form contains the following fields and options:

- Payee Name:** A text input field containing 'Ali'.
- Draft Type:** Two radio button options: 'Domestic' (selected) and 'International'.
- Draft Favouring:** A text input field containing 'John Elton'.
- Draft Payable at City:** A dropdown menu with 'New York' selected.
- Delivery Location:** Two radio button options: 'Branch Near Me' (selected) and 'My Address'.
- City:** A dropdown menu with 'USA' selected.
- Branch Near Me:** A dropdown menu with 'FLEXCUBE UNIVERSAL BRANCH FOR CI' selected.

Below the form, there are two buttons: 'Add' (with a plus icon) and 'Cancel' (with an X icon). At the bottom left, there is a link 'Back to Dashboard'. At the bottom right, there is a scroll-up arrow. A callout box on the right side of the form contains the following text:

**Transfer money faster than ever!**

Transferring money towards payees is easy and quick.

Perform a one-time Payee addition maintenance and simply select the payee while transferring funds.

The payee details will be listed on the screen for verification and all you have to do is enter the amount and date of transfer to initiate the transfer.

At the bottom of the page, there is a footer: 'Copyright ZigBank Ltd. All Rights Reserved | Security Information | Terms and Conditions'.

### Field Description

Field Name	Description
------------	-------------

<b>Payee Name</b>	Specify the name by which the payee is to be identified.
-------------------	--

<b>Draft Type</b>	Select the type of draft to be associated with the Payee. The options are:
-------------------	---

- Domestic
- International

<b>Draft Favouring</b>	The name of the payee i.e. the intended recipient of the funds.
------------------------	---

**Draft Payable at City** The name of the city in which the draft is payable.

**Delivery Location** Select the option to identify where you would like the draft delivered.  
The options are:

**P  
a  
y  
e  
e**

- **Branch Near Me:** On selecting this option, the fields by which you can select a branch of the bank at which the draft is to be delivered will appear.
- **My Address:** You can select an address at which the draft is to be delivered

The following section appears if you select the **Branch Near Me** option as draft delivery location.

**City** Select the name of the city to filter the branches so as to be able to select a branch in the city of your choice.

**Branch Near Me** Select the branch at which you would like the draft to be delivered.

**Branch Address** The complete name and address of the selected branch is displayed.

The following section appears if you select the **My Address** option as draft delivery location.

**Select Address** Select the address at which you want the draft to be delivered.  
The options are:

**t  
h  
e  
n  
a  
m  
e**

- Work
- Residence
- Postal

**Address Details** The details of the selected address are displayed.

**o**

f the payee for identification.

2. In the **Draft Type** field, select the option **Domestic**.
3. In the **Draft Favoring** field, enter the name of the payee of the draft.
4. In the **Draft Payable at City** field, select the name of the city at which the draft is to be payable.
5. In the **Delivery Location** field, select the appropriate draft delivery option.
  - a. If you select **Branch Near Me** option;
    - i. From the **City** list, select the city so as to filter the branches based on city of choice.

- ii. From the **Branch Near Me** list, select the branch at which you want the draft to be delivered.  
The complete address of selected branch appears.
  - b. If you select the **My Address** option;
    - i. From the **Select Address** list, select the option of choice.  
The complete address of the user as maintained corresponding to the selected address appears.
- 6. Click **Add** to add a payee.  
OR  
Click **Cancel** to cancel the transaction.  
OR  
Click the **Back to Dashboard** link, to navigate to the dashboard.
- 7. The **Add Payee - Review** screen appears. Verify the details, and click **Confirm**.  
OR  
Click **Back** to navigate back to the previous screen.  
OR  
Click **Cancel** to cancel the transaction and to navigate back to 'Dashboard'.
- 8. The success message appears along with the draft details.  
Click **Go to Dashboard**, to navigate to the dashboard.  
OR  
Click **More Payment Options** to access other payment options.  
OR  
Click **Pay Now** to initiate draft issuance to the added payee.  
OR  
Click **Setup Payee Limits** to assign limits (daily and/or monthly) to the payee's account.

## 9.2 Add Payee – International Demand Draft

An International Draft payee is created to initiate a request to issue a draft which is payable at a location outside the country. The user provides the payee details, the details of draft to be issued in favor of and the payable location.

**To create an international demand draft payee:**

## Demand Draft – International Demand Draft Payee

The screenshot shows the 'Add Payee' screen in the ZigBank interface. The 'Demand Draft' tab is selected. The form contains the following fields and options:

- Payee Name:** Sara
- Draft Type:** Domestic (unselected), International (selected)
- Draft Favouring:** Samuel
- Draft Payable at Country:** BRITISH INDIAN OCEAN TERRITORY (dropdown)
- City:** London
- Delivery Location:** Branch Near Me (selected), My Address (unselected)
- City:** London (dropdown)
- Branch Near Me:** CITI BANK (dropdown)
- Branch Details:** CITI BANK, Unit 1, Block A, London, GB

At the bottom, there are 'Add' and 'Cancel' buttons. A 'Back to Dashboard' link is also present. A callout box on the right contains the following text:

**Transfer money faster than ever!**

Transferring money towards payees is easy and quick.

Perform a one-time Payee addition maintenance and simply select the payee while transferring funds.

The payee details will be listed on the screen for verification and all you have to do is enter the amount and date of transfer to initiate the transfer.

### Field Description

Field Name	Description
------------	-------------

<b>Payee Name</b>	Specify the name by which the payee is to be identified.
-------------------	--

<b>Draft Type</b>	Select the type of draft to be associated with the Payee. The options are:
-------------------	---

- Domestic
- International

<b>Draft Favoring</b>	The name of the payee i.e. the intended recipient of the funds.
-----------------------	---

<b>Draft payable at Country</b>	The name of the country in which the draft is payable. This field is enabled if the <b>International</b> option is selected as <b>Draft Type</b> .
---------------------------------	---

<b>Draft payable at City</b>	The name of the city in which the draft is payable.
------------------------------	---



Field Name	Description
<b>Delivery Location</b>	Select the option to identify where you would like the draft delivered. The options are: <ul style="list-style-type: none"> <li>• <b>Branch Near Me:</b> On selecting this option, the fields by which you can select a branch of the bank at which the draft is to be delivered will appear</li> <li>• <b>My Address:</b> You can select an address at which the draft is to be delivered</li> </ul>

The following section appears if you select the **Branch Near Me** option as draft delivery location.

**City** Select the name of the city to filter the branches so as to be able to select a branch in the city of your choice.

**Branch Near Me** Select the branch at which you would like the draft to be delivered.

**Branch Address** The complete name and address of the selected branch is displayed.

The following section appears if you select the **My Address** option as draft delivery location.

**Select Address** Select the address at which you want the draft to be delivered.  
The options are:

- Work
- Residence
- Postal

**Address Details** The details of the selected address are displayed.

1. In the **Payee Name** field, enter the name of the payee for identification.
2. In the **Draft Type** field, select **International** option.
3. In the **Draft Favouring** field, enter the name of the payee of the draft.
4. In the **Draft Payable at Country** field, select the country in which the draft is to be payable.
5. In the **Draft Payable at City** field, select the name of the city at which the draft is to be payable.
6. In the **Delivery Location** field, select the appropriate draft delivery option.
  - a. If you select **Branch Near Me** option;
    - i. From the **City** list, select the city so as to filter the branches based on city of choice.

- ii. From the **Branch Near Me** list, select the branch at which you want the draft to be delivered.  
The complete address of selected branch appears.
  - b. If you select **My Address** option;
    - iii. From the **Select Address** list, select the option of choice.  
The complete address of the user as maintained corresponding to the selected address appears.
- 7. Click **Add** to add a payee.  
OR  
Click **Cancel** to cancel the transaction.  
OR  
Click the **Back to Dashboard** link, to navigate to the dashboard.
- 8. The **Add Payee - Review** screen appears. Verify the details, and click **Confirm**.  
OR  
Click **Back** to navigate back to the previous screen.  
OR  
Click **Cancel** to cancel the transaction and navigate back to 'Dashboard'.
- 9. The success message appears along with the draft details.  
Click **Go to Dashboard**, to navigate to the dashboard.  
OR  
Click **More Payment Options** to access other payment options.  
OR  
Click **Pay Now** to initiate draft issuance to the added payee.  
OR  
Click **Setup Payee Limits** to initiate set-up daily limits and monthly limits.

## **FAQs**

### **1. When can I make the payment to newly added payee?**

After successfully adding a payee, you may proceed to transfer funds only after the cooling period (the time set by the bank during which fund transfer is not allowed to a newly added payee) or you may set a future date for the transaction to take place.

### **2. If I delete or edit a payee, what will happen to the in-flight transactions?**

Payee modification or deletion will not have any impact on the transactions which are initiated towards the payee and that are pending further processing.

[Home](#)

## 10. Manage Biller

Billers are configured as the bank's customers in the host system. The bank designates a single account to each such customer as the "collection" account. This account is used to post all payments made from various users.

The online banking application enables users to register and maintain these billers towards whom utility payments are to be made frequently or on a regular basis.

### Prerequisites:

- Transaction access is provided to the retail user
- Billers are maintained in the host system
- Admin Biller Category mapping is done

### Features supported in the application

- View Biller
- Edit Biller
- Create Biller
- Delete Biller

### Workflow

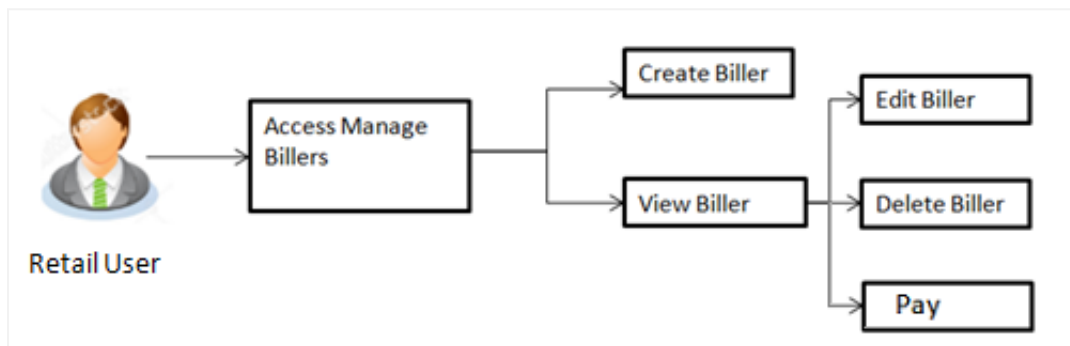

### How to reach here:

*Dashboard > Payments Widget > Manage Payees & Billers*

OR

*Dashboard > Toggle Menu > Payments > Manage Payees & Billers*

OR

*Dashboard > Payments Menu > Manage Payees & Billers*

### 10.1 Manage Billers – Summary

The summarized views of all the billers maintained by the user are displayed on the screen.

#### To manage billers:

1. In the **Manage Whom** field, select the **Biller** option.  
All the registered billers are listed down by their names defined at the time of biller creation.

## Manage Billers - Summary

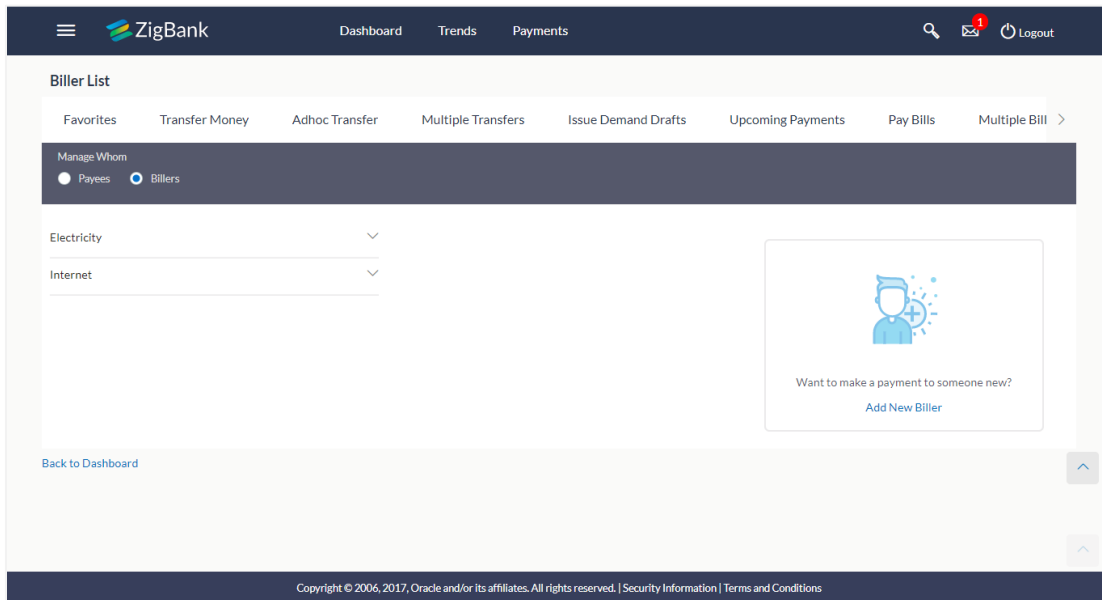



### Field Description

Field Name	Description
<b>Manage Whom</b>	The option to either manage payees or billers.
The following fields appear if the option ' <b>Billers</b> ' is selected under the field ' <b>Manage Whom</b> '.	
<b>Billers List</b>	Displays the list of registered billers.
<b>Category</b>	The category of the registered biller.
The following fields appear when the  icon (expand option) is selected against any biller name.	
<b>Biller Name</b>	The name of registered biller.
<b>Relationship Number</b>	The unique relationship number that the user has with the biller.

- From the **Biller List**, select and click on the biller whose details you want to view. A card displaying the **Biller Name** and **Relationship Number** appears.  
OR  
Click **Add New Biller** to add a new biller.

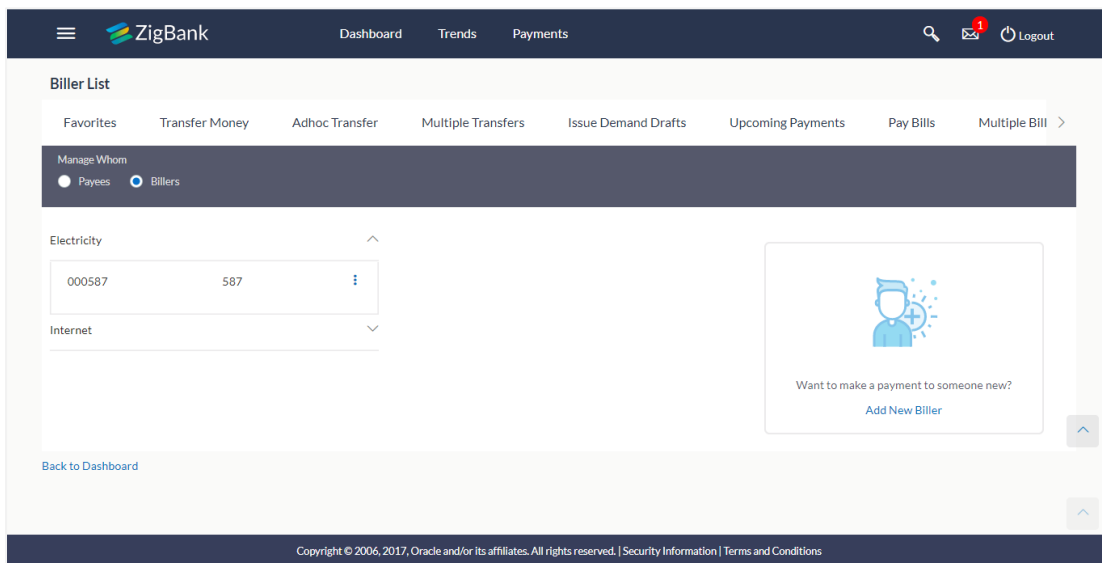
## Manage Billers – Expanded View



3. Click  against a specific biller and then click **View/Edit**. The **View/ Edit Biller** screen appears.
- OR
- Click **Pay** to pay the bills.
- OR
- Click **Delete** to delete the biller.

## 10.2 View Biller Details

The user can view the details of billers created under a party by selecting the option 'View/Edit' provided against each biller record on the summary page.

### To View the biller details:

1. From the **Biller List**, select and click on the biller whose details you want to view. A card displaying the Biller Name and Relationship Number appears.
2. Click  and then click **View/Edit**. The **View/ Edit Biller** screen appears.

## View/ Edit Biller

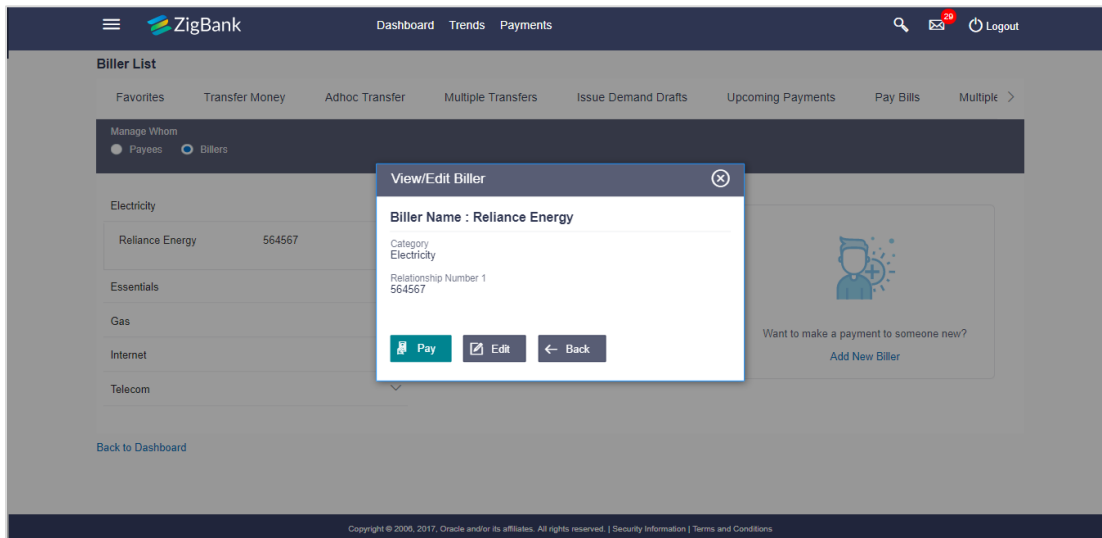

### Field Description

Field Name	Description
<b>Biller Name</b>	The name of registered biller.
<b>Category</b>	The category of the registered biller.
<b>Relationship Number</b>	Relationship number of the user with the biller.

3. Click **Pay** to initiate a bill payment against the selected biller.  
OR  
Click **Edit** to edit the biller details. The **View/ Edit Biller** screen with values in editable form appears.  
OR  
Click **Back** to navigate back to the previous screen.

## 10.3 Edit Biller

Users are provided with the facility to modify the relationship numbers associated with the billers.

### To edit biller relationship numbers:

1. From the **Biller List**, select and click on the expand option provided against the biller whose details you want to edit.  
A card displaying the Biller Name and Relationship Number appears.
2. Click  and then click **View/Edit**. The **View/ Edit Biller** screen appears.
3. Click **Edit** to edit the biller. The **View/ Edit Biller** screen appears with values in editable form.

## Edit Biller

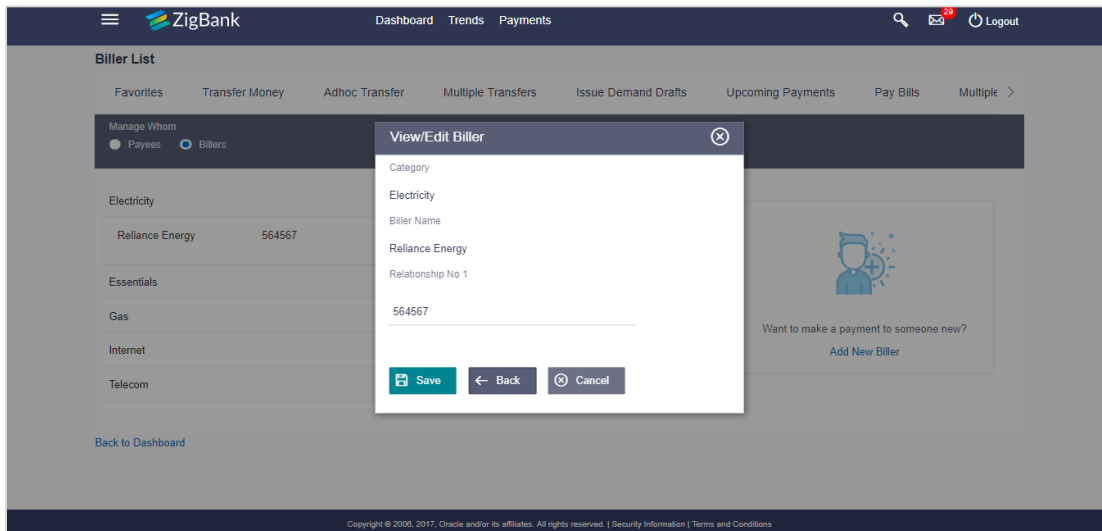

### Field Description

Field Name	Description
<b>Category</b>	The category of the registered biller.
<b>Biller Name</b>	The name of registered biller.
<b>Relationship Number</b>	Relationship number of the user with the biller.

- In the **Relationship Number** field edit the values if required.
- Click **Save** to save the changes.  
OR  
Click **Back** to navigate back to the previous screen.  
OR  
Click **Cancel** to cancel the operation.
- The success message of edit biller appears.  
Click **Back to Dashboard** to navigate to the dashboard.

## 10.4 Add Biller

Users can create billers by specifying the category to which the biller is associated, e.g. electricity, cable, etc., the name of the biller and the relationship number that the user holds with the biller.

### To register a biller:

- Click the **Add New Biller** link in the Manage Billers screen. The **Add Biller** screen appears.

### Add Biller

The screenshot shows the 'Add Biller' form in the ZigBank application. The form has three main input fields: 'Category' with a dropdown menu showing 'Electricity', 'Biller Name' with a dropdown menu showing 'Reliance Energy', and 'Relationship No 1' with a text input field containing '11231'. Below these fields are two buttons: a green 'Add' button and a grey 'Cancel' button. To the right of the form is a callout box with a blue header 'Adding a biller is as easy as 1-2-3!' and three numbered steps: 1. Search for the biller you want to add on the basis of biller category; 2. Select the biller and enter your unique relationship number with the biller; 3. Your biller has now been added! Proceed to Pay Bills to pay your bills. The top navigation bar includes 'Dashboard', 'Trends', and 'Payments' links, along with a search icon, a notification icon with '20', and a 'Logout' button. The footer contains copyright information: 'Copyright © 2008, 2017, Oracle and/or its affiliates. All rights reserved. | Security Information | Terms and Conditions'.

## Field Description

Field Name	Description
<b>Category</b>	Select the category to which the biller belongs.
<b>Biller Name</b>	Select the name by which the biller is to be identified.
<b>Relationship Number</b>	Specify the relationship of the user with the biller.

2. From the **Category** list, select the category to which the biller belongs.
3. From the **Biller Name** list, select the registered biller name towards whom payments are to be made.
4. In the **Relationship Number** field, enter the relationship number that you hold with the biller.
5. Click **Add** to add a biller.  
OR  
Click **Cancel** to cancel the operation and navigate back to 'Dashboard'.
6. The **Add Biller – Review** screen appears. Verify the details, and click **Confirm**.  
OR  
Click **Back** to navigate back to the previous screen.  
OR  
Click on **Cancel** to cancel the operation and to navigate back to 'Dashboard'.
7. The success message appears along with the biller details.  
Click **Go to Dashboard**, to navigate to the dashboard.  
OR  
Click **More Payment Options** to access other payment options.  
OR  
Click **Pay Now** to initiate a bill payment towards the added biller.



## 10.5 Delete Biller

Using this option, you can delete the registered biller created under a party.

### To delete a biller:

1. From the biller category list, click on the expand option provided against the category of choice.  
The selected category is expanded to display all the billers associated with the category.
2. Click the  option against a specific Biller and then click **Delete**. The **Delete Biller** pop up window appears with a warning message prompting the user to confirm the deletion.

### Delete Biller

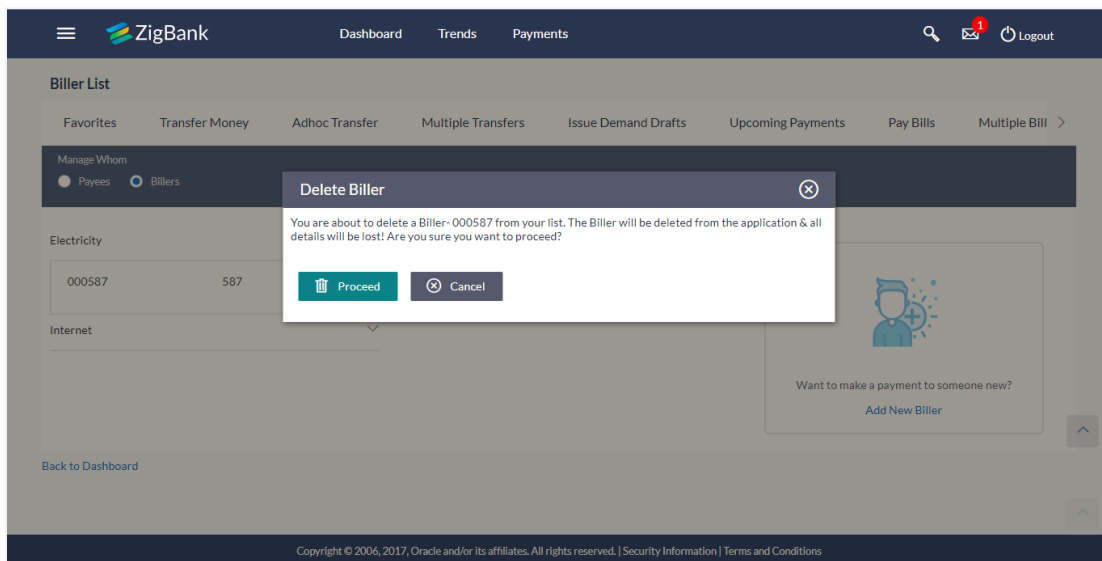

3. Click **Proceed** to proceed with the deletion request.  
OR  
Click **Cancel** to cancel the deletion process.
4. The screen confirming biller deletion appears.  
Click **Go to Dashboard** to navigate to the dashboard.  
OR  
Click **More Payment Options** to access other payment options.

## FAQs

1. **Can I delete billers that I no longer need to make payments to?**  
Yes. You can choose to delete the billers that you no longer need.
2. **When can I make the payment to newly added biller?**  
After successfully adding a biller, you may proceed to pay bills towards the specific biller immediately.
3. **If I delete or edit a biller, what will happen to the in-flight transactions?**

Biller modification or deletion will not have any impact on the transactions which are initiated towards the payee and that are pending further processing.

[Home](#)

## 11. Issue Demand Draft

The Issue Demand Draft transaction enables users to request the bank to issue demand drafts towards payees. In order to initiate a demand draft issue request, the user has to first ensure that the payee i.e. the recipient of the demand draft is registered as a demand draft payee through the Manage Payees feature. Once the payee is registered, the user can initiate a request to the bank to issue a demand draft by specifying details such as the amount for which the draft is to be drawn, the account from which the funds are to be debited as well as the date on which the draft is to be drawn.

### Prerequisites:

- Transaction and account access is provided to the retail user
- Transaction working window is maintained
- Required payees are maintained
- Transaction limits are assigned to user to perform the transaction

### Features supported in application

The user can request for two types of demand drafts:

- Domestic Demand Draft – Where the draft is payable within the country
- International Demand Draft – Where the draft is payable outside the country

### Workflow

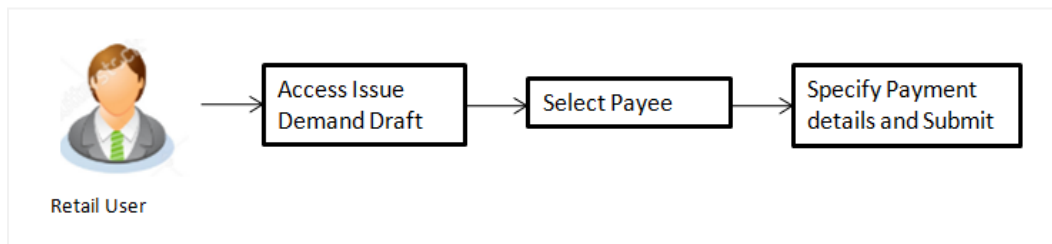

### How to reach here:

*Dashboard > Toggle Menu > Payments > Issue Demand Drafts*

*OR*

*Dashboard > Payments Menu > Issue Demand Drafts*

## 11.1 Demand Draft

A user can initiate a request for a Demand Draft using this transaction. All Demand Draft payees (Domestic and International Demand Draft payees) created by the user are listed for selection. Details of the payee are auto populated on the transaction screen once a selection has been made. The user is then required to fill in details such as the source account to be debited, the amount for which the draft is to be drawn and the date on which the draft is payable, in order to initiate the demand draft request.

### Demand Draft

### Field Description

Field Name	Description
------------	-------------

<b>Favouring</b>	Select the payee to whom the demand draft is to be issued. All the demand draft payees maintained will be listed for selection.
------------------	--

<b>Draft Details</b>	The delivery details of the draft that include the mode of delivery and address at which the draft will be delivered are displayed once the payee is selected.
----------------------	--

<b>Currency</b>	The currency in which the draft is to be issued. In case the draft being issued is a domestic demand draft, the currency will be the local currency of the country.
-----------------	--

Field Name	Description
<b>Amount</b>	The amount for which the draft is to be issued.
<b>View Limits</b>	Link to view the transaction limits.
<b>Scheduled on</b>	The facility to specify the date on which the demand draft is to be issued. The options are: <ul style="list-style-type: none"> <li>• Now: draft is to be drawn on the same day</li> <li>• Later: draft is to be drawn with a date in the future</li> </ul>
<b>Transfer On Date</b>	The date on which the draft is to be issued. This field appears if the option <b>Later</b> is selected from the <b>Scheduled On</b> list.
<b>Transfer From</b>	Select the source account from which the funds are to be debited towards the issue of the demand draft.
<b>Balance</b>	Select the source account from which the funds are to be transferred.
<b>Note</b>	Narrative for the transaction.

#### To issue a demand draft:

1. From the **Favoring** list, select the payee to whom demand draft needs to be issued. The details of the selected payee appear.  
OR  
Click  if you want to select a different payee.
2. From the **Currency** list, select the preferred currency.
3. In the **Amount** field, enter amount for which the draft needs to be issued.
4. In the **Scheduled On** field, select the option to indicate whether the draft is to be issued for the same day or a date in the future.
  - a. If you select the **Now** option, the draft will be issued on the same day.  
OR
  - b. If you select the option **Later**, select the date for when the draft is to be drawn.
5. From the **Transfer From** list, select the account from which funds need to be drawn.
6. Click **Issue** to initiate the request for the issue of the demand draft.  
OR  
Click **Cancel** to cancel the transaction.
7. The **Demand Draft – Review** screen appears. Verify the details, and click **Confirm**.  
OR  
Click **Back** to navigate back to the previous screen.  
OR  
Click **Cancel** to cancel the operation and to navigate back to 'Dashboard'.
8. The **Verification** screen appears if the transaction is configured for 2 factor authentication.
9. The success message appears, along with the host reference number and draft details.  
Click **Go to Dashboard**, to navigate to the dashboard.

OR

Click **More Payment Options** to access other payment options.

## **FAQs**

1. **Can I initiate a future dated demand draft issuance request?**

You can initiate a future dated demand draft issuance request using the Schedule Later option.

2. **What happens if I have set up a future dated draft issuance request, but don't have enough funds in my account on the transaction date for the transfer?**

Balance check will not be performed at the time of transaction initiation with future date. The transaction will get declined in case of insufficient funds in the account on the given transaction date.

3. **What happens if the transaction amount is less than the set Transaction Limit?**

You will not be able to proceed with the initiation of the demand draft issuance if the amount you have specified is less than that of the set minimum transaction limit.

4. **How will I receive a physical copy of a demand draft?**

The bank will operationally issue a draft and mail it to the address that you have selected as the delivery address in the payee maintenance screen.

[Home](#)

## 12. Bill Payment

The Bill payment feature enables users to pay their utility bills online. Through this feature, users are able to pay their bills quickly, securely and at their own convenience.

### Prerequisites:

- Transaction and account access is provided to the retail user
- Transaction working window is maintained
- Billers are maintained
- Transaction limits are assigned to the user to perform the transaction.

### Features supported in application

- Bill Payment

### Workflow

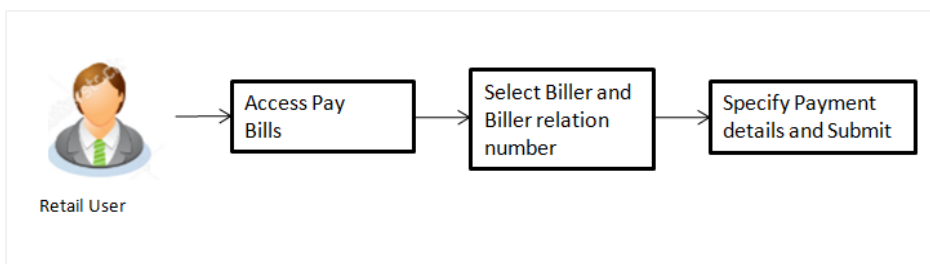

### How to reach here:

*Dashboard > Payments Widget > Pay Bills*

OR

*Dashboard > Toggle Menu > Payments > Pay Bills*

OR

*Dashboard > Payments Menu > Pay Bills*

### 12.1 Pay Bills

Users can initiate bill payments towards billers that are already registered in the system. All billers that are previously registered are listed for selection. Once the user selects a biller, the details of that biller are populated on the screen for the user to verify. The user can proceed to initiate the bill payment transaction by specifying details such as the amount to be paid, the account from which the funds are to be transferred, the bill date and bill number.

## Pay Bills

The screenshot displays the 'Pay Bills' page in the ZigBank mobile application. The top navigation bar includes 'Dashboard', 'Trends', and 'Payments'. The main content area is titled 'Pay Bills' and contains several input fields for bill details. A sidebar on the right provides information about the benefits of using the service. At the bottom, there are 'Pay' and 'Cancel' buttons, and a 'Back to Dashboard' link.

### Field Description

Field Name	Description
<b>Biller Name</b>	Select the name of the biller towards whom bill payment is to be made.
<b>Relationship Number</b>	Select the relationship number that you have with the biller against which you want to make a bill payment.
<b>Amount</b>	Specify the amount that you want to pay.
<b>View Limits</b>	Link to view the transaction limits.
<b>Pay From</b>	Select the source account that is to be debited to make the bill payment.
<b>Balance</b>	On selecting a source account, the net balance of the account appears below the <b>Pay From</b> field.
<b>Bill Date</b>	Specify the date on which the bill was generated.
<b>Bill Number</b>	Enter the number of the bill that is to be paid.



Field Name	Description
<b>Note</b>	Add a note against the bill payment transaction, if required.

### To pay a bill:

1. From the **Biller Name** list, select the biller towards whom you wish to make a payment.  
OR  
Click the [Add New Biller](#) link if there are no billers mapped to make bill payment.
2. From the **Relationship Number** list, select your relationship number with the biller against which you wish to make a bill payment.
3. In the **Amount** field, enter the bill amount.
4. From the **Pay From** list, select the source account to be debited.
5. In the **Bill Date** field, specify the date on which the bill was generated.
6. In the **Bill Number** field, enter the number of the bill that is to be paid.
7. Click **Pay** to initiate the bill payment transaction.  
OR  
Click **Cancel** to cancel the operation and to navigate back to 'Dashboard'.  
OR  
Click [Back to Dashboard](#), to navigate to the dashboard.
8. The **Pay Bills - Review** screen appears. Verify the details, and click **Confirm**.  
OR  
Click **Back** to navigate back to the previous screen.  
OR  
Click **Cancel** to cancel the operation and to navigate back to 'Dashboard'.
9. The success message appears along with the host reference number and payment details.  
Click [Go to Dashboard](#) to navigate to the dashboard.  
OR  
Click [More Payment Options](#) to access other payment options.  
OR  
Click [Add Favourite](#) to mark the transaction as favorite.

## FAQs

1. **Can I initiate future dated bill payments?**  
No, you can only initiate bill payments to be processed immediately using this transaction.
2. **Where do I find my Relationship Number?**  
Please check the bill sent to you by the respective biller. Alternatively, it is also available in the SMS/Email communication send to you by your biller.
3. **Can I make a payment towards a biller who is currently not registered in my biller list?**  
No, using this transaction, you can make payments only to registered billers.
4. **Can I set an option to auto pay the bill amount of already generated bills?**  
No, currently this option is not supported.

[Home](#)

## 13. Multiple Bill Payments

The Multiple Bill Payments transaction enables users to pay multiple utility bills simultaneously from a single screen.

### Prerequisites:

- Transaction access is provided to retail user
- Billers are maintained
- Transaction limits are assigned to user to perform the transaction

### Workflow

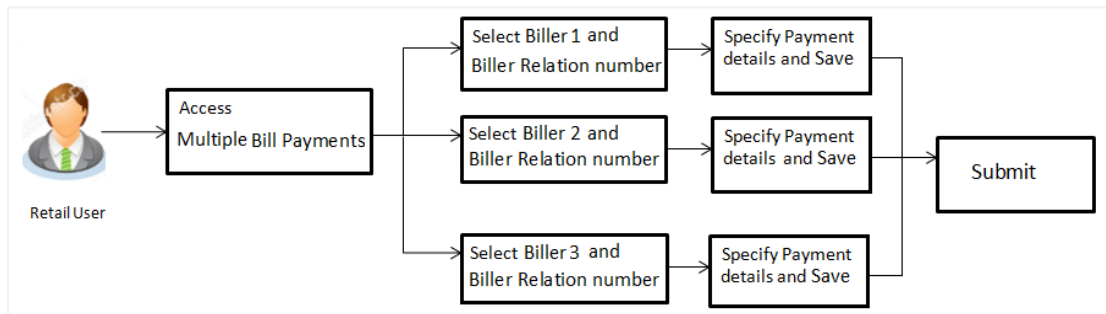

### How to reach here:

*Dashboard > Toggle Menu > Payments > Multiple Bill Payments*

*OR*

*Dashboard > Payments Menu > Multiple Bill Payments*

## Multiple Bill Payments

☰ ZigBank
Dashboard Trends Payments Logout

### Multiple Bill Payments

[Favorites](#)
[Transfer Money](#)
[Adhoc Transfer](#)
[Multiple Transfers](#)
[Issue Demand Drafts](#)
[Upcoming Payments](#)
[Pay Bills](#)
[More](#)

**Bill 1**

Bill Name  
000032 🗑️

Relationship No.  
11115

Amount  
£1,000.00

[View Limits](#)

Pay From  
xxxxxxxxxxxx0016

Balance : £554.90

Bill Date  
01 Jan 2014 📅

Bill Number  
456677

Note (optional)  
Electricity bill payment

56 Characters Left

Save
Make a copy & save
Reset Fields



**Paying bills has never been easier!**

No more keeping track of all your bills, issuing cheques or having to deal with late payment fines. Now simply pay all your utility bills at once from a single screen.

**Bill 2**

Bill Name  
000518 🗑️

Relationship No.  
14141

Amount  
£1,200.00

[View Limits](#)

Pay From  
xxxxxxxxxxxx0016

Balance : £554.90

Bill Date  
02 Jan 2014 📅

Bill Number  
32333

Note (optional)

80 Characters Left

Save
Make a copy & save
Reset Fields

**Add Another Payment**

✔ Submit
✖ Cancel

[Back to Dashboard](#)

Copyright © 2006, 2017, Oracle and/or its affiliates. All rights reserved. | [Security Information](#) | [Terms and Conditions](#)

## Field Description



Field Name	Description
------------	-------------

The following fields are applicable for each individual bill payment record that comprises the multiple bill payments transaction:

<b>Billers Name</b>	Select the biller towards whom you wish to make a payment.
<b>Relationship No.</b>	Select the relationship number that you hold with the biller.
<b>Amount</b>	Specify the amount that you wish to pay.
<b>View Limits</b>	Link to view the transaction limits applicable to the user.
<b>Pay From</b>	Select the source account from which funds are to be deducted towards the bill payment.
<b>Balance</b>	On selecting a source account, the net balance of the account appears below the Pay From field.
<b>Bill Date</b>	Bill generation date.
<b>Bill Number</b>	Specific bill number.
<b>Note</b>	You can add a note against the bill payment, if required.

### To pay the bill:

1. From the **Billers Name** list, select the preferred biller.
2. From the **Relationship No.** list, select your biller relationship number.
3. In the **Amount** field, enter the bill amount.
4. From the **Pay From** list, select the source account from which funds are to be utilized towards making the bill payment.
5. From the **Bill Date** list, select the bill generation date.
6. In the **Bill Number** field, enter the number of the bill to be paid.
7. Click **Save** to save the bill payment details.  
OR  
Click **Make a Copy & Save**, if you want to save the current bill payment record and also copy the details onto the next record.  
OR  
Click **Reset Fields** to clear the details entered in the record.
8. Repeat Steps 1 to 7 for subsequent bill payment records.  
OR  
Click **Add Another Payment** if you want to add another bill payment record without saving the current record.

9. Click  against a saved bill to edit the bill payment details of that record.  
OR  
Click  against a bill payment record to delete that record.
10. Click **Submit** to submit all the bill payment records.  
OR  
Click **Cancel** to cancel the operation and navigate back to 'Dashboard'.  
OR  
Click Back to Dashboard link, to navigate to the dashboard.
11. The Multiple Bill Payments - Review screen appears. Verify the details, and click Submit.  
OR  
Click **Back** to navigate to the previous screen.  
OR  
Click **Cancel** to cancel the operation and navigate back to 'Dashboard'.
12. The Verification screen appears if the transaction is configured for Two Factor Authentication.  
Enter the verification code and click **Submit**.
13. The success message appears, along with the transaction reference number.  
Click Go to Dashboard, to navigate to the dashboard.  
OR  
Click More Payment Options to access other payment options.  
OR  
Click **Status** to view the status of bill payments.  
The **Multiple Bill Payments – Status** screen appears on which the status of each individual bill payment appears. In case any bill payment record has failed, the reason for failure is also displayed against the specific record.

### Multiple Bill Payment – Status

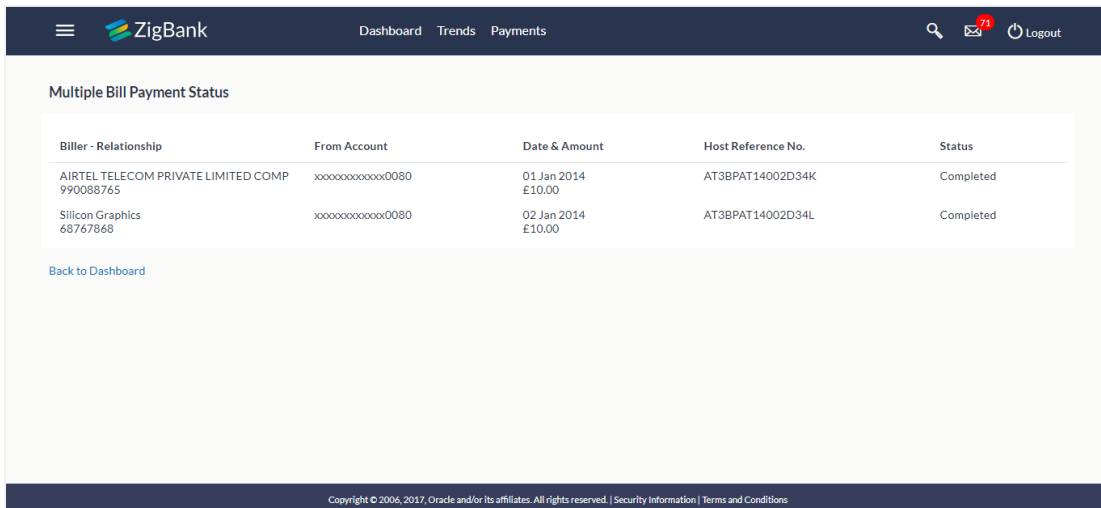

Biller - Relationship	From Account	Date & Amount	Host Reference No.	Status
AIRTEL TELECOM PRIVATE LIMITED COMP 990088765	xxxxxxxxxxxx0080	01 Jan 2014 £10.00	AT3BPAT14002D34K	Completed
Silicon Graphics 68767868	xxxxxxxxxxxx0080	02 Jan 2014 £10.00	AT3BPAT14002D34L	Completed

[Back to Dashboard](#)

Copyright © 2006, 2017, Oracle and/or its affiliates. All rights reserved. | Security Information | Terms and Conditions

**Field Description**

<b>Field Name</b>	<b>Description</b>
<b>Billers - Relationship</b>	The name of registered biller and the relationship number of the customer with the biller.
<b>From Account</b>	The source account from which funds are to be deducted towards the bill payment.
<b>Date &amp; Amount</b>	The date on which the bill was generated and the amount transferred towards payment of the bill.
<b>Host Reference Number</b>	The unique number generated on completion of the transaction in the Core Banking application.
<b>Status</b>	The status of the transaction.
<b>Failure Reason</b>	The reason for which a bill payment failed is displayed against the specific record.

14. Click the [Back to Dashboard](#) link to navigate to the Dashboard.

**FAQs**

**1. Is there any limit on the number of bills that can be paid at a time through multiple bill payments?**

Yes, the limit as defined by the bank will be in place. You will be displayed an error message if you try to add another bill payment record once this limit has been met.

**2. Are there limits to payment amounts?**

Yes, there are daily limits and monthly limits set by the bank for payments of bills.

**3. Will I receive a confirmation when my payments are processed?**

Yes. Once you make multiple bill payments, you'll see a confirmation screen which has a link to view the status of each bill payment. You can also download the electronic receipts of individual bill payment transactions.

[Home](#)

## 14. Manage Debtors

In order to request money from debtors via the Request Money feature, the user needs to first add a debtor. The following details are required to be captured in order to save a debtor:

- Debtor Name
- Debtor IBAN
- BIC Code of the Debtor's bank account
- Nick Name

Once a debtor is created through the, Add Debtor feature, the user can initiate a request for money to be transferred from the debtor's account via the Request Money feature.

### Pre-Requisites

- Transaction access is provided to the retail user

### Features supported in the application

- View Debtor
- Add Debtor
- Delete Debtor

### Workflow

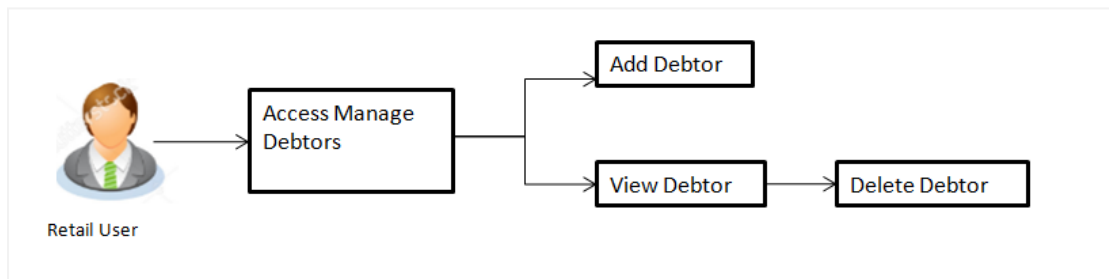

### How to reach here:

*Dashboard > Toggle Menu > Payments > Manage Debtors*

### To manage debtors:

1. All the debtor names appear on **Manage Debtors** screen.

## Manage Debtors

The screenshot displays the 'Manage Debtors' page in the ZigBank application. The page header includes the ZigBank logo, navigation links for 'Dashboard', 'Trends', and 'Payments', and a search icon with a notification badge showing '149' and a 'Logout' button. The main content area is titled 'Manage Debtors' and has two tabs: 'Request Money' and 'Manage Debtors'. Below the tabs is a 'Debtor List' section with a search field labeled 'Search By Nickname'. The list contains 13 entries, each with a name and a vertical ellipsis menu icon. To the right of the list is a callout box with a person icon and the text 'Want to request payment from someone new?' and a button labeled 'Add New Debtor'. At the bottom left of the list area is a 'Back to Dashboard' link. The footer of the page contains the text 'Copyright ZigBank Ltd. All Rights Reserved | Security Information | Terms and Conditions'.

### Field Description

Field Name	Description
------------	-------------

<b>Debtor List</b>	Displays the list of debtors.
--------------------	-------------------------------

<b>Debtor Name</b>	The name by which the debtor is identified as defined at the time of debtor addition.
--------------------	---

- From the **Debtor List**, select and click on a debtor whose details you want to view.  
OR  
In the **Search by Nickname** field, enter the nickname of the debtor whose details you want to view and click .  
OR  
Click the **Add New Debtor** link to create a new debtor.  
OR  
Click **Back to Dashboard**, to navigate to the dashboard.
- Click and then click **View Details**. The **Manage Debtors - Debtor Details** screen appears.  
OR  
Click the **Add New Debtor** link to create a new debtor.  
OR  
Click **Back to Dashboard**, to navigate to the dashboard.



## 14.1 Manage Debtors – View

### Manage Debtors – Debtor Details

The screenshot shows the ZigBank 'Manage Debtors' interface. A modal window titled 'Debtor Details' is open, displaying the following information:

Debtor Name : Sara	
IBAN 58167791	BIC code HSBLGB99 HSBLGB99 HSBLGB99 GB

Below the details is a green 'Request' button. The background shows a list of debtors with search and add options.

#### Field Description

Field Name	Description
------------	-------------

<b>Debtor Name</b>	The name of the debtor as defined at the time of debtor creation.
--------------------	---

<b>IBAN</b>	International bank account number (IBAN) of the debtor.
-------------	---

<b>BIC Code</b>	Bank Identifier code (BIC) of the debtor bank.
-----------------	--

1. Click **Request** if you want to request money.

## 14.2 Add Debtor

Using this option you can add a debtor.

### To add a new debtor:

1. In the Manage Debtors screen, click the Add New Debtor link to add a new debtor. The **Add Debtors** screen appears.

### Add Debtor

The screenshot shows the 'Add Debtor' form in the ZigBank interface. The form has the following fields and values:

- Debtor Name:** Sara J
- Debtor IBAN:** 58167791
- Bank BIC Code:** HSBLGB99
- Nickname:** Sara

There is a 'Reset' button below the BIC code field. At the bottom of the form are 'Add' and 'Cancel' buttons. A sidebar on the right contains a tip titled 'Speed up your payments!' with instructions on how to tag transactions as favourites.

### Field Description

Field Name	Description
<b>Debtor Name</b>	Enter the name of the debtor.
<b>Debtor IBAN</b>	Specify the International bank account number (IBAN) of the debtor.
<b>Bank BIC Code</b>	Enter the Bank Identifier code (BIC) of the debtor's bank.
<b>Nickname</b>	Enter a nickname by which you want to identify the debtor.



2. In the **Debtor Name** field, enter debtor name from whom the amount is to be received.
  3. In the **Debtor IBAN** field, enter debtor IBAN number.
  4. In the **Bank BIC Code** field, enter BIC code of the debtor bank.
- OR

- Click **Verify** to verify the entered BIC code with the bank details based on BIC code.  
 OR  
 Click **Lookup BIC Code** to lookup for the BIC search. Displays the bank details.
5. In the **Nickname** field, enter the debtor's nickname.
  6. Click **Add**.  
 OR  
 Click **Cancel** to cancel the transaction.
  7. The **Review** screen appears. Verify the details, and click **Confirm**.  
 OR  
 Click **Back** to navigate back to the previous screen.  
 OR  
 Click **Cancel** to cancel the transaction.
  8. The success message appears.  
 Click **Go to Dashboard** to navigate to the dashboard.  
 OR  
 Click **More Payment Options** to go to other payment options.

## 14.3 Delete Debtor

### Delete Debtor

The screenshot displays the ZigBank 'Manage Debtors' interface. At the top, there is a navigation bar with 'ZigBank' logo, 'Dashboard', 'Trends', and 'Payments' tabs, along with search, notification (149), and Logout icons. Below the navigation bar, the 'Manage Debtors' section is active, with a sub-tab for 'Manage Debtors'. A 'Debtor List' table is visible, containing entries like 'debtor07\_06\_2017', 'debtor1', 'Debtor2', 'Sara', 'debtor172', 'debtor345', 'debtor3456', 'debtor987', 'debtornew', 'new', 'debtors', 'newdebtor00987', and 'newdebtors'. A modal dialog box titled 'Delete Debtor' is overlaid on the table, containing the text: 'You are about to delete a Debtor- Sara from your list. The Debtor will be deleted from the application & all details will be lost! Are you sure you want to proceed?'. The dialog has two buttons: 'Proceed' (with a trash icon) and 'Cancel' (with a close icon). At the bottom of the interface, there is a 'Back to Dashboard' link and a footer with copyright information: 'Copyright ZigBank Ltd. All Rights Reserved | Security Information | Terms and Conditions'.

1. From the **Debtor List**, select and click on the debtor record which you want to delete.  
OR  
Enter the nickname of the debtor which you want to delete and click .  
OR  
Click the **Add New Debtor** link to create a new debtor.  
OR  
Click **Back to Dashboard**, to navigate to the dashboard.
2. Click  and then click **Delete**. The **Manage Debtors - Delete Debtor** message box with a message prompting the user to confirm the deletion appears.
3. Click **Proceed** to proceed with the deletion request.  
OR  
Click **Cancel** to cancel the deletion process.
4. The success message of deletion appears.  
Click **Go to Dashboard** to navigate to the dashboard.  
OR  
Click **More Payment Options** to go to other payment options.

[Home](#)

## 15. Request Money

The Request Money feature targets users who have receivables due from various individuals which are also periodic in nature. As the name suggests the user needs to initiate a request to pull money from the debtor (the person from whom the money is due to be received) by providing details of the debtor through debtor maintenance.

### Prerequisites:

- Transaction and account access is provided to the retail user
- Transaction working window is maintained
- Debtors are maintained

### Features supported in application

Request money allows the user to

- Initiate SEPA Request Money

### Workflow

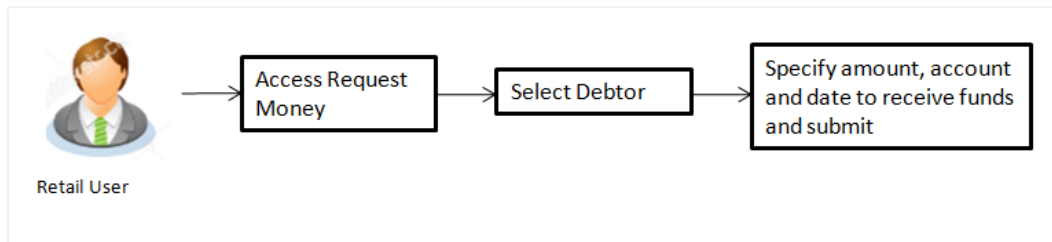

### How to reach here:

*Dashboard > Payments Widget > Request Money*

*OR*

*Dashboard > Toggle Menu > Payments > Request Money*

### To initiate a Request Money transaction:

## Request Money

The screenshot shows the 'Request Money' interface in the ZigBank mobile app. At the top, there's a navigation bar with 'Dashboard', 'Trends', and 'Payments'. The main content area has two tabs: 'Request Money' (active) and 'Manage Debtors'. The form fields are as follows:

- Request From:** Brienne Tarth
- Amount:** ₹10,000.00
- Request In:** xxxxxxxxxxxxxxx0095
- Balance:** £18,090.00
- Receive On:** 30 Jun 2017
- Note (Optional):** 80 Characters Left

At the bottom of the form are 'Request' and 'Cancel' buttons. A 'Back to Dashboard' link is also present. On the right side, there is a 'PIN Safety Tips' sidebar with the following text:

**PIN Safety Tips**

Memorise your PIN. Do not write it down anywhere, and certainly never on the card itself.

Your card is for your own personal use. Do not share your PIN or card with anyone, not even your friends or family.

Keep your card private. Don't let anyone see it when you're out in public.

NoOfy your bank if you move; you want to make sure your statements and other information follow you to your new address and don't end up in anyone else's hands.

### Field Description

Field Name	Description
------------	-------------

<b>Request From</b>	Select the debtor from whom you need to request money.
<b>Amount</b>	Specify the amount that is to be requested from the debtor.
<b>Request In</b>	Select the account to be credited with the specified amount.
<b>Balance</b>	On selecting an account in the Request In field, the net balance of that account is displayed below the field.
<b>Receive On</b>	Specify the date on which the money needs to be received.
<b>Note</b>	Narrative for the transaction.

1. From the **Request From** list, select the debtor from whom the money is to be requested, and subsequently select the account maintained under debtor.

**Note:** If there is no debtor mapped, click on **Add Debtor**. And add the bank account details of the debtor.

2. In the **Amount** field, enter amount that needs to be transferred.
3. From the **Request In** list, select the account that needs to be credited with the amount.

4. From the **Receive On** list, select the date on which the money needs to be received.
5. In the **Note** field, enter for a note against the transaction, if required.
6. Click **Request**.  
OR  
Click **Cancel** to cancel the transaction.  
OR  
Click **Back to Dashboard**, to navigate to the dashboard.
7. The **Review** screen appears. Verify the details, and click **Confirm**.  
OR  
Click **Cancel** to cancel the transaction.
8. The success message appears along with the reference number.  
Click **Go to Dashboard** to navigate to the dashboard.  
OR  
Click **More Payment Options** to go to other payment options.  
OR  
Click **Manage Debtors** to create/edit/view debtors.

## **FAQs**

### 1. **When will I receive the money I requested?**

After the recipient of the request responds with a payment, the money will be automatically deposited in the account that you have identified at the time of request initiation.

### 2. **Can I cancel a request for money?**

No, a request once initiated cannot be cancelled.

[Home](#)

## 16. Repeat Transfers

**Repeat Transfers**, also referred to as Standing Instructions or Standing Orders, are instructions given by a payer (bank account holder) to the bank to transfer a specific amount to another account at regular intervals.

Once initiated, these transfers are executed repeatedly till the end date.

The application has simplified the user's task of initiating repetitive payments by introducing the **Repeat Transfers feature**. Through this feature, users can set instructions for funds to be transferred at regular intervals towards registered payees or to the user's own accounts. Once initiated, the details of these transfers can be viewed in the **View Repeat Transfers** screen. The user can also cancel a repeat transfer instruction, if so desired, from the View Repeat Transfers screen.

### Pre-Requisites

- Transaction and account access is provided to the retail user
- Transaction working window is maintained
- Payees are maintained
- Purpose of Payments are maintained
- Transaction limits are assigned to the user

### Features supported in application

- Set Repeat Transfers
- View Repeat Transfers
- Stop Repeat Transfers

### Workflow

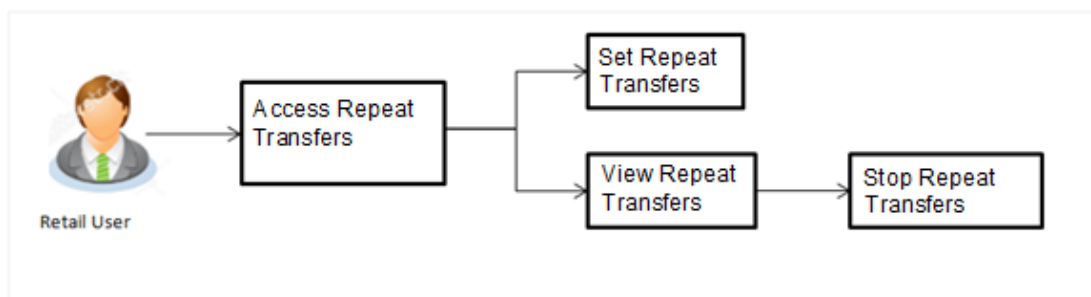



**How to reach here:**

*Dashboard > Payments Widget > View Repeat Transfers > Repeat Transfers*  
OR

*Dashboard > Upcoming Payments Widget > Setup Repeat Transfers > Repeat Transfers*  
OR

*Dashboard > Toggle Menu > Payments > Repeat Transfers*  
OR

*Dashboard > Payments Menu > Upcoming Payments > Set Repeat Transfers*

## 16.1 View Repeat Transfers

The **View Repeat Transfers** feature enables users to view all the repeat transfers that have been previously initiated. The user can select any repeat transfer transaction in order to view extensive details of that particular transaction. The details include basic transfer details such as source account, beneficiary account, amount of transfer, etc.; execution details encompassing the frequency of transfers and the start and end dates as well as the payment history which lists down the status of each executed transfer instruction. The reason of failure is also defined against instructions that have failed execution.

### Repeat Transfers

**Repeat Transfers**

[View Repeat Transfers](#) [Set Repeat Transfers](#)

Search By Account Name

Transfer To	Transfer From	Transfer Type	Next Payment	Amount	
Jones Weber xxxxxxxxxxxx0028	xxxxxxxxxxxx0029	Domestic	14 Jan 2019	£1,000.00	⋮
Own Account xxxxxxxxxxxx0040	xxxxxxxxxxxx0029	Self	14 Jan 2019	£100.00	⋮
accanme xxxxxxxxxxxx6666	xxxxxxxxxxxx0018	Domestic	30 Jul 2018	£100.00	⋮

Page 1 of 1 (1-3 of 3 Items)

[Back to Dashboard](#)

Copyright © 2006, 2017, Oracle and/or its affiliates. All rights reserved. | Security Information | Terms and Conditions

## Field Description

Field Name	Description
<b>Transfer To</b>	Displays the name, address and account number along with the account nickname of the payee.
<b>Transfer From</b>	The source account number in masked format from which funds are transferred towards the payee account.
<b>Transfer Type</b>	Type of transfer e.g. Domestic, Own, Internal.
<b>Next Payment</b>	The date on which the next payment is scheduled.
<b>Amount</b>	Amount of the set Repeat Transfer.

### To view the Repeat Transfers:

1. Click  against a specific repeat transfer record. The following options appear: View/ Stop
2. Select the option **View** to view the details of the particular repeat transfer. The **View Repeat Transfer** details screen appears.  
OR  
Click **Stop** if you want to stop the repeat transfer.  
OR  
Click **Back to Dashboard**, to navigate to the dashboard.

## Repeat Transfers - View Repeat Transfer

The screenshot shows the ZigBank interface for viewing a repeat transfer. The main screen displays a table with columns for 'Transfer To', 'Transfer From', and 'Amount'. A modal window is open, showing details for a 'Repeat Transfer - Domestic AT3ZPCP140034XHD'. The modal includes fields for 'Transfer To', 'Transfer From', 'Next Payment', 'Amount', 'Purpose', and 'Note'. Below these is an 'Execution Details' section with 'Start Date', 'End Date', and 'Frequency'. At the bottom of the modal are 'Stop' and 'Back' buttons.

### Field Description

Field Name	Description
<b>Transfer Type and Transaction Reference Number</b>	The transfer type involved i.e. internal, domestic, etc. as well as the transaction reference number are displayed..
<b>Transfer To</b>	Displays the name and account number along with the account nickname of the payee.
<b>Transfer From</b>	The source account number along with the account nickname, if maintained, is displayed.
<b>Next Payment</b>	The date on which the next payment is scheduled.
<b>Amount</b>	Amount of the set Repeat Transfer.
<b>Purpose</b>	Purpose of transfer.
<b>Note</b>	A note, if added, by the user at the time of transfer initiation is displayed.
<b>Execution Details</b>	

Field Name	Description
<b>Start Date</b>	The start date of the repeat transfer execution i.e. the date on which the repeat transfer first starts being executed.
<b>End Date</b>	The last date on which repeat transfer instructions are executed.
<b>Frequency</b>	The frequency in which the repeat transfer is executed.
<b>Payments History</b>	
<b>Execution Date</b>	The date on which the repeat transfer was executed.
<b>Status</b>	The status of the repeat transfer. The status can be: <ul style="list-style-type: none"> <li>• Active</li> <li>• Failed</li> </ul>
<b>Reason for Failure</b>	The reason why the specific transfer instruction failed is displayed against those transfer records that have failed to be executed.

3. Click **Stop** if you want to stop the repeat transfer.  
OR  
Click **Cancel** to close the **View Repeat Transfer** screen.

## 16.2 Stop Repeat Transfers

The option to stop a repeat transfer instruction is provided on the View Repeat Transfers summary screen as well as View Repeat Transfer details page only against those transactions that have instructions pending to be executed.

## Repeat Transfers - Stop Repeat Transfer

The screenshot shows the ZigBank 'View Repeat Transfer' page. A modal window titled 'Stop Repeat Transfer' is displayed over a table of repeat transfers. The modal contains the following information:

- Transfer To: Own Account xxxxxxxxxxxx0040
- Transfer From: xxxxxxxxxxxx0029
- Amount: £100.00
- Frequency: Every month
- Next Payment: 14 Jan 2019

The modal has two buttons: 'Stop' and 'Back'.

### Field Description

Field Name	Description
------------	-------------

<b>Transfer To</b>	Displays the name and account number along with the account nickname of the payee.
--------------------	--

<b>Transfer From</b>	The account from which the amounts are transferred towards the beneficiary or destination account.
----------------------	--

<b>Amount</b>	Amount of the set Repeat Transfer.
---------------	------------------------------------

<b>Frequency</b>	The frequency in which the amounts are transferred from the source account to the destination account.
------------------	--

<b>Next Payment</b>	The date on which the next payment is scheduled.
---------------------	--

### To stop a Repeat Transfer:

1. Click  against the specific repeat transfer record. The following options appear: View/ Stop

2. Select the option **Stop** to cancel the repeat transfer. The **Stop Repeat Transfer** details screen appears.  
OR  
Click **View** to view the details of the repeat transfer.  
OR  
Click **Back to Dashboard**, to navigate to the dashboard.
3. Click **Stop** to stop the repeat transfers maintained for the account.  
OR  
Click **Back** to navigate to the previous screen.
4. A message prompting the user to confirm the cancelling of **Repeat Transfer** appears.  
Click **Stop** to confirm.  
OR  
Click **Back** to navigate to the previous screen.  
OR  
Click **Cancel** to close the message window and to return to the previous screen.
5. A message confirming that the repeat transfer has been stopped/cancelled appears.  
Click **Go to Dashboard**, to navigate to the dashboard.  
OR  
Click **More Payment Options** to access other payment options.

## 16.3 Set Repeat Transfers

Through the Set Repeat Transfers feature, a user can initiate an instruction for repeat transfers to be executed towards a payee or account for a specific amount at a certain frequency.

### Set Repeat Transfer – Existing Payee

The following screen displays the fields that are populated when the **Existing Payee** option is selected in the **Transfer Type** field

**Set Repeat Transfer**

View Repeat Transfers | **Set Repeat Transfers**

Transfer Type  
 Existing Payee  My Accounts

Payee  
 All

Ali Hassan - All  
 Account Number: AT30025430013 | Account Type: Domestic | Account Name: Ali Hassan  
 Bank Details: HDFC0000017, HDFC Bank Ltd, 361, Saks Avenue, Chennai, HDFC0000017

Transfer From  
 xxxxxxxxxx0080

Balance: £9,990,837.49

Amount  
 GBP £100.00  
[View Limits](#)

Transfer Frequency  
 Monthly

Start Transferring  
 01 Dec 2017

Stop Transferring  
 on  after  
 28 Feb 2018

Purpose  
 Transaction is the payment of interest.

Note (Optional)  
 80 Characters Left

[Setup](#) [Cancel](#)

[Back to Dashboard](#)

**What are the benefits?**

- No more waiting in queues, issuing cheques or late payment hassles.
- Consolidated view of all billers and payment history.
- Make all payments and recharges at one place.
- Get SMS Alerts for bill presentations, payments etc.
- Avail of automatic payments by setting a standing instruction upto a defined amount threshold or schedule payments at a later date.

Copyright © 2006, 2017, Oracle and/or its affiliates. All rights reserved. | [Security Information](#) | [Terms and Conditions](#)

## Field Description

Field Name	Description
------------	-------------

<b>Transfer Type</b>	This option enables the user to identify whether the transfers are to be made towards registered payees or towards the user's own accounts.
----------------------	---

The options are:

- Existing Payee
- My Accounts (User's own account)

<b>Payee</b>	Select the payee towards whom the transfers are to be made.
--------------	---

<b>Account Number</b>	On selecting the payee, the account number associated with the payee appears.
-----------------------	---

<b>Field Name</b>	<b>Description</b>
<b>Account Type</b>	Type of account or transfer type associated with the payee appears, once a payee is selected.
<b>Account Name</b>	The name of the payee in the bank account appears.
<b>Bank Details</b>	The details of the bank i.e. the name and address of the bank's branch in which the payee's account is held appears.
<b>Transfer From</b>	Select the source account from which the funds are to be transferred.
<b>Balance</b>	On selecting a source account, the net balance of the account appears below the Transfer From field.
<b>Currency</b>	Select the currency in which the transfer is to take place. Currency is defaulted to destination account currency for Internal Transfers and local currency for Domestic Transfers.
<b>Amount</b>	Specify the amount to be transferred per frequency.
<b>View Limits</b>	Link to view the transaction limits applicable to the user.
<b>Transfer Frequency</b>	The frequency in which the repeat transfers are to be executed. The options are: <ul style="list-style-type: none"> <li>• Daily</li> <li>• Weekly</li> <li>• Fortnightly</li> <li>• Bi-monthly</li> <li>• Monthly</li> <li>• Quarterly</li> <li>• Semi-Annually</li> <li>• Annually</li> </ul>
<b>Start Transferring</b>	The date on which the first repeat transfer is to be executed.
<b>Stop Transferring</b>	Select the option by which to specify when the repeat transfers are to stop being executed. The following two options are available: <ul style="list-style-type: none"> <li>• On: Select this option if you wish to specify a date on which the last transfer is to be executed.</li> <li>• After: Select this option if you wish to specify the number of repeat transfers that are to be executed as part of the instruction.</li> </ul>



Field Name	Description
<b>Date</b>	Specify the date on which the last transfer is to be executed. This field appears if the option <b>On</b> is selected in the <b>Stop Transferring</b> field.
<b>Instances</b>	Number of instances. This field appears if the option <b>After</b> is selected in the <b>Stop Transferring</b> field.
<b>Purpose</b>	Select the purpose for which the repeat transfer instruction is being initiated.
<b>Note</b>	Narrative for the transaction.

#### To setup Repeat Transfer instructions towards an Existing Payee:

1. In the **Transfer Type** field, select the **Existing Payee** option.
2. From the **Payee** list, select the payee to whom fund needs to be transferred, and subsequently select the specific account of the payee towards which the transfers are to be made.
3. From the **Transfer From** list, select the account from which the transfers are to be made.
4. From the currency list, select the preferred currency.
5. In the **Amount** field, enter the amount to be transferred at regular intervals.
6. From the **Transfer Frequency** list, select the frequency in which the repeat transfer to be executed.
7. From the **Start Transferring field**, select the date on which the Repeat transfers are to start being executed.
8. In the **Stop Transferring** field, select the option by which to specify when the repeat transfers are to stop being executed.
  - a. If you have selected the option **On**, specify the date on which the repeat transfers are to stop being executed.
  - b. If you have selected the option **After**, specify the number of instances after which the repeat transfers are to stop i.e. if you specify the number 10, only 10 transfers will be initiated at the specified frequency.
9. From the **Purpose** list, select the appropriate purpose for which the repeat transfer instruction is being initiated.
10. In the **Note** field, specify a narrative for the transaction.
11. Click **Setup**.  
OR  
Click **Cancel** to cancel the transaction.  
OR  
Click the **Back to Dashboard** link to navigate to the dashboard.
12. The **Review** screen appears. Verify the details, and click **Confirm**.  
OR  
Click **Back** to navigate to the previous screen.

OR

Click **Cancel** to cancel the transaction.

13.A message confirming that the transaction has been initiated appears along with the host reference number and payment details.

Click **Go to Dashboard**, to navigate to the dashboard.

OR

Click **More Payment Options** to access other payment options.

### Set Repeat Transfer – My Accounts

The following screen displays the fields that are populated when the **My Accounts** option is selected in the **Transfer Type** field.

The screenshot displays the 'Set Repeat Transfer' page on the ZigBank website. The page is titled 'Set Repeat Transfer' and has two tabs: 'View Repeat Transfers' and 'Set Repeat Transfers'. The 'Transfer Type' is set to 'My Accounts'. The form includes the following fields:

- Account Number:** xxxxxxxxxxx0080 (Balance: £9,990,637.49)
- Transfer From:** xxxxxxxxxxx0069 (Balance: £10,934,587.66)
- Amount:** GBP £10.00
- Transfer Frequency:** Weekly
- Start Transferring:** 18 Dec 2017
- Stop Transferring:** 31 Jan 2018
- Note (Optional):** 80 Characters Left

A 'What are the benefits?' box on the right side of the form lists the following benefits:

- No more waiting in queues, issuing cheques or late payment hassles.
- Consolidated view of all billers and payment history.
- Make all payments and recharges at one place.
- Get SMS Alerts for bill presentments, payments etc.
- Avail of automatic payments by setting a standing instruction upto a defined amount threshold or schedule payments at a later date.

The page footer contains the text: Copyright © 2006, 2017, Oracle and/or its affiliates. All rights reserved. | Security Information | Terms and Conditions

**Field Description**

<b>Field Name</b>	<b>Description</b>
<b>Transfer Type</b>	<p>This option enables the user to identify whether the transfers are to be made towards registered payees or towards the user's own accounts.</p> <p>The options are:</p> <ul style="list-style-type: none"> <li>Existing Payee</li> <li>My Accounts (User's own account)</li> </ul>
<b>Account Number</b>	Select the account towards which repeat transfers are to be made. All the accounts of the user are displayed.
<b>Balance</b>	On selecting an account number, the net balance of the account appears below the <b>Account Number</b> field.
<b>Transfer From</b>	Select the source account from which the funds are to be transferred.
<b>Balance</b>	On selecting a source account, the net balance of the account appears below the <b>Transfer From</b> field.
<b>Currency</b>	The currency in which the transfer is to take place. The currency is defaulted as the beneficiary account currency.
<b>Amount</b>	Specify the amount to be transferred.
<b>View Limits</b>	Link to view the transaction limits applicable to the user.
<b>Transfer Frequency</b>	<p>The frequency in which the repeat transfers are to be executed.</p> <p>The options are:</p> <ul style="list-style-type: none"> <li>Daily</li> <li>Weekly</li> <li>Fortnightly</li> <li>Bi-monthly</li> <li>Monthly</li> <li>Quarterly</li> <li>Semi-annually</li> <li>Annually</li> </ul>
<b>Start Transferring</b>	The date on which the first repeat transfer is to be executed.

Field Name	Description
<b>Stop Transferring</b>	<p>Select the option by which to specify when the repeat transfers are to stop being executed.</p> <p>The following two options are available:</p> <ul style="list-style-type: none"> <li>• On: Select this option if you wish to specify a date on which the last transfer is to be executed</li> <li>• After: Select this option if you wish to specify the number of repeat transfers that are to be executed as part of the instruction</li> </ul>
<b>Date</b>	<p>Specify the date on which the last transfer is to be executed.</p> <p>This field appears if the option <b>On</b> is selected against the <b>Stop Transferring</b> field.</p>
<b>Instances</b>	<p>Number of instances.</p> <p>This field appears if the option <b>After</b> is selected against the <b>Stop Transferring</b> field.</p>
<b>Note</b>	Narrative for the transaction.

#### To setup Repeat Transfer instructions towards My Accounts (Own Account):

1. In the **Transfer Type** field, select the My Accounts option.
2. From the **Account Number** list, select the account to which the fund transfers need to be made.
3. From the **Transfer From** list, select the account from which the transfers need to be made.
4. In the **Amount** field, enter the amount to be transferred at regular intervals.
5. From the **Transfer Frequency** list, select the frequency in which the repeat transfers are to be executed.
6. From the **Start Transferring** field, select the date on which the Repeat transfers are to start being executed.
7. In the **Stop Transferring** field, select the option by which to specify when the repeat transfers are to stop being executed.
  - a. If you have selected the option **On**, specify the date on which the repeat transfers are to stop being executed.
  - b. If you have selected the option **After**, specify the number of instances after which the repeat transfers are to stop i.e. if you specify the number 10, only 10 transfers will be initiated at the specified frequency.
8. Specify a narrative for the transaction in the note field.
9. Click **Setup**.
  - OR
  - Click **Cancel** to cancel the transaction.
  - OR
  - Click the **Back to Dashboard** link to navigate to the dashboard.

10. The **Review** screen appears. Verify the details, and click **Confirm**.  
OR  
Click **Back** to navigate to the previous screen.  
OR  
Click **Cancel** to cancel the transaction.
11. A message confirming that the transaction has been initiated appears along with the host reference number and payment details.  
Click **Go to Dashboard**, to navigate to the dashboard.  
OR  
Click **More Payment Options** to access other payment options.

## **FAQs**

### **1. Can I cancel a Repeat Transfer instruction?**

Yes, you can cancel Repeat Transfer transactions provided that the instruction has some instructions that have not yet been executed. You cannot reverse transfers that have already been initiated.

Once an instruction has been cancelled, it will no longer be visible on the View Repeat Transfer screen.

### **2. What happens if I have set up a transfer for a future date, but on that date I don't have enough funds in my account to cover the transfer?**

In this case, the transfer will not be made. Transfers are executed only if there are funds available in your account.

[Home](#)

## 17. Favorites

This feature enables users to mark transactions as favorite. By doing so, the user is able to quickly access these transactions and is able to use these transactions as templates to initiate new transactions. This feature is beneficial to users who frequently initiate transfers towards the same recipients with similar details.

The user is able to mark a transaction as favorite by selecting the option provided on the specific transaction's confirmation page.

The following types of payment transactions can be marked as Favorite transactions.

- Payments made to an account
- Bill Payments

Once a transaction is marked as favorite, it is displayed in the user's favorite transaction list. The user has to simply select the transaction of choice from the list displayed. Once a transaction is selected, the system displays the details of the transaction in editable mode. The user is able to make changes, if required and can submit the transaction for processing.

### Prerequisites:

- Transaction and account access is provided to the retail user

### Features supported in the application

- View Favorite Transaction Details
- Initiate a Payment
- Remove Transaction from Favorite List

### Workflow

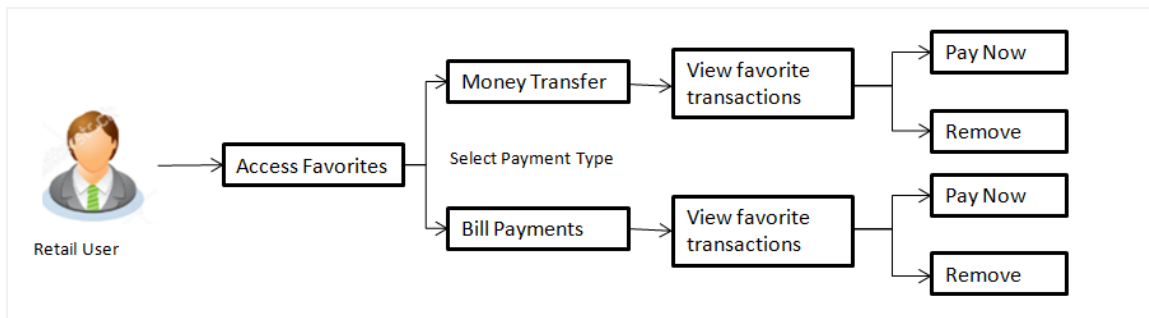

### How to reach here:

*Dashboard > Payments Widget > Favorites*  
 OR  
*Dashboard > Toggle Menu > Payments > Favorites*  
 OR  
*Dashboard > Payments Menu > Favorites*

## 17.1 Favorites – Summary

The summarized views of all the payment transactions marked as favorite are displayed on the screen.

The screen is divided into two sections –

- **Money Transfer** - Transactions marked as favorite for 'Account' type of payments are listed under this section
- **Bill Payments** - Transactions marked as favorite for 'Bill Payment' type of payments are listed under this section

The user is provided with the option to search for a favorite transaction on the basis of the payee name, in case of money transfers or the biller name, in case of bill payments. The user can view and initiate transactions using these favorite transactions as templates and can also delete any transaction from the favorite list.

### To view and initiate a favorite transaction:

1. All the favorite transactions appear as a list on the **Favorites – Summary** screen.

### Favorites – Summary

Search By Payee

Payee	Transfer Type	Amount
Jack	International Transfer	€1,000.00
Self	Self Transfer	£100.00
RichInNick	Internal Transfer	£1,000.00

Page 1 of 1 (1-3 of 3 items) | < 1 >

Speed up your payments!

Tag any transaction as favourite on the Payment Receipt Screen, so the next time you can execute the same transaction with fewer clicks.

Simple steps to fast track your banking transactions:

- Select the transaction you wish to perform
- Funds Transfer or Bill Payment
- Complete your transaction
- Tag your transaction as favourite on the Payment Receipt Screen

Back to Dashboard

Copyright © 2006, 2017, Oracle and/or its affiliates. All rights reserved. | Security Information | Terms and Conditions

2. Select the relevant favorite transaction record and click

Click **Pay Now** to initiate the transaction.

The details of the selected transaction appear in the respective payment transfer screen.

OR

Click **Remove** to remove the transaction from the favorite list.

OR

In the **Search By Payee/ Search By Biller Name**, enter the payee/ biller name of the transaction which you want to initiate and click .

OR

Click **Back to Dashboard**, to navigate to the dashboard.

## Transaction initiation through Favorites

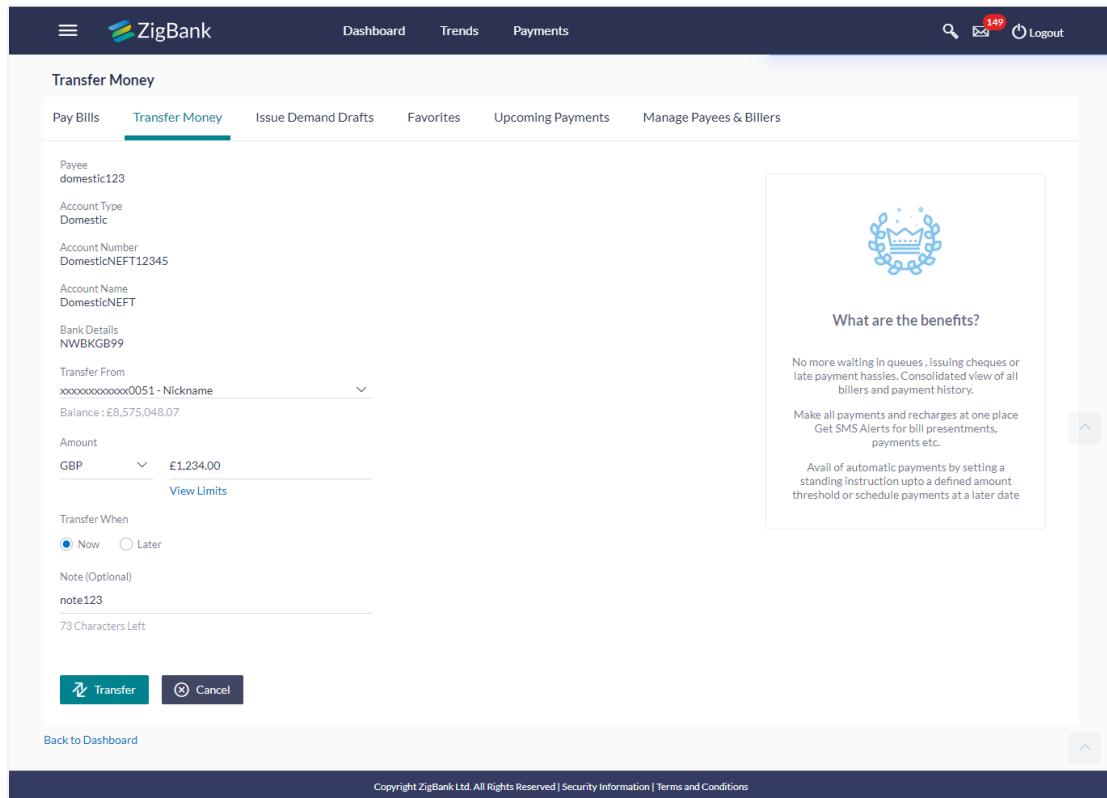

The screenshot displays the ZigBank 'Transfer Money' interface. At the top, there's a navigation bar with 'Dashboard', 'Trends', and 'Payments'. The main content area is titled 'Transfer Money' and includes tabs for 'Pay Bills', 'Transfer Money', 'Issue Demand Drafts', 'Favorites', 'Upcoming Payments', and 'Manage Payees & Billers'. The 'Transfer Money' tab is active, showing a form for initiating a transfer. The form includes fields for 'Payee' (domestic123), 'Account Type' (Domestic), 'Account Number' (DomesticNEFT12345), 'Account Name' (DomesticNEFT), and 'Bank Details' (NWBKGB99). The 'Transfer From' field is set to 'xxxxxx0051 - Nickname'. The 'Amount' is £1,234.00, and the 'Transfer When' is set to 'Now'. There is a 'Note (Optional)' field with 'note123'. At the bottom, there are 'Transfer' and 'Cancel' buttons. A 'Back to Dashboard' link is also present. On the right side, there's a sidebar with a 'What are the benefits?' section, which lists benefits like 'No more waiting in queues', 'Make all payments and recharges at one place', and 'Avail of automatic payments by setting a standing instruction'.

3. To initiate a transaction, click **Transfer**.

OR

Click **Cancel** to cancel the transaction.

## 17.2 Remove Favorites

**To remove a transaction from the favorite list:**

1. In the **Favorite Summary** screen, select the relevant payee/ biller name.

OR

In the **Search By Payee/ Search By Biller Name**, enter the payee/ biller name of the transaction which you want to remove and click .

2. Click  and then click **Remove** to remove the transaction from favorites list.

The **Delete Favorites** message box appears with a message prompting the user to confirm the deletion.

OR

Click **Pay Now** to initiate a transaction using the specific favorite transaction as a template.



## Remove Favorites- Confirm

The screenshot shows the ZigBank interface with a 'Delete Favorite' modal dialog open. The dialog contains the text 'Are you sure you want to delete favorite for domestic123' and two buttons: 'Proceed' (with a trash icon) and 'Cancel' (with an 'X' icon). The background is dimmed, showing a table of favorite transactions and a tip section titled 'Speed up your payments!'.

Payee	Transfer Type	Amount	More
domestic123	Domestic Transfer		
internal123	Internal Transfer Instruction		
Self	Self Transfer	£123.00	⋮
Self	Self Transfer	£500.00	⋮
Self	Self Transfer	£10.00	⋮
Theon	International Transfer Instruction	£100.00	⋮
domestic123	Domestic Transfer Instruction	£2,000.00	⋮

Page 1 of 1 (1-7 of 7 items) | < 1 >

Back to Dashboard

Copyright ZigBank Ltd. All Rights Reserved | Security Information | Terms and Conditions

3. Click **Proceed** to proceed with the deletion request.  
OR  
Click **Cancel** to cancel the deletion process.
4. The message confirming the removal of the transaction from the favorite list appears.  
Click **Back to Dashboard**, to navigate to the dashboard.

## **FAQs**

**1. If I add a transaction to 'Favorites', where will this transaction be reflected and what benefit will I gain from this?**

The transaction will be saved in the 'Favorites' list. You can then use this transaction by selecting it from this list the next time you want to initiate a similar payment. The details will be prepopulated on the screen thus saving you the time and effort of having to enter all the details again.

**2. What type of transactions can be saved as favorite?**

You can mark the following types of transactions as favorite:

- Payments made to an account
- Bill Payments

**3. Can I edit the details if I am re-initiating a transaction from my favorite transaction list?**

Yes, you can edit the details and re-initiate a transaction by selecting a favorite transaction.

**4. What happens when I add a transaction in my favorite list?**

Once a transaction is marked as favorite it is displayed in the user's favorite list. The user can directly initiate a transfer using favorite transactions; all the transaction details are auto populated in the respective fields. The user can make required changes in the details and submit the transaction for processing.

[Home](#)

## 18. Upcoming Payments Inquiry

Upcoming payment is a unique feature available to users that displays the list of payments initiated by the user that are awaiting processing either on the same day or on a future date.

Through this feature, the user is able to view at a glance, all the payment transactions that are to be processed on the same day or in the near future. All the payment transactions are listed down as records with details such as the date on which the payment is due for processing, the amount of payment, description and the type of payment i.e. whether it is a one time payment or a repeat transfer.

The following payment transactions will be reflected in 'Upcoming Payments' as per the date of the transaction:

- Future Dated Transfers
- Future Dated Demand Drafts.
- Repeat Transfers

### Prerequisites:

- Transaction and account access is provided to Retail user
- Upcoming payments are maintained under accounts

### Features supported in application

Following transactions are allowed under Upcoming Payments

- View Upcoming Payments
- Cancel Upcoming Payment

### Workflow:

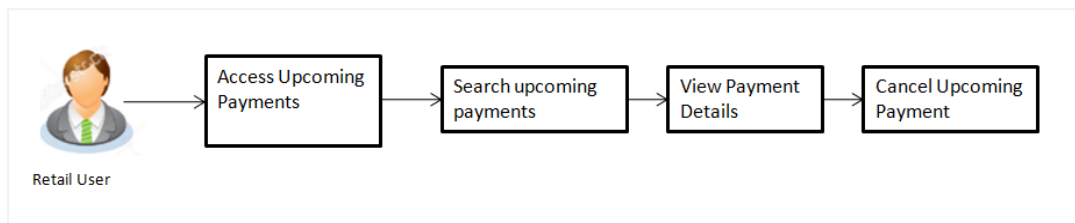

### How to reach here:

*Dashboard > Upcoming Payments Widget > View All > Upcoming Payments Inquiry*

OR

*Dashboard > Toggle Menu > Payments > Upcoming Payments Inquiry*

OR

*Dashboard > Payments Menu > Upcoming Payments > Upcoming Payments Inquiry*

## 18.1 Upcoming Payment – Summary

The summarized view of all your upcoming payments starting with the most recent, are listed on Upcoming Payment Inquiry screen.

### To view all the upcoming payments:

1. All the scheduled upcoming payments appear as records on **Upcoming Payments Inquiry** screen.

OR

In the **Search by Description**, enter the description of the upcoming payment which you want view and click .

### Upcoming Payments Inquiry - Summary

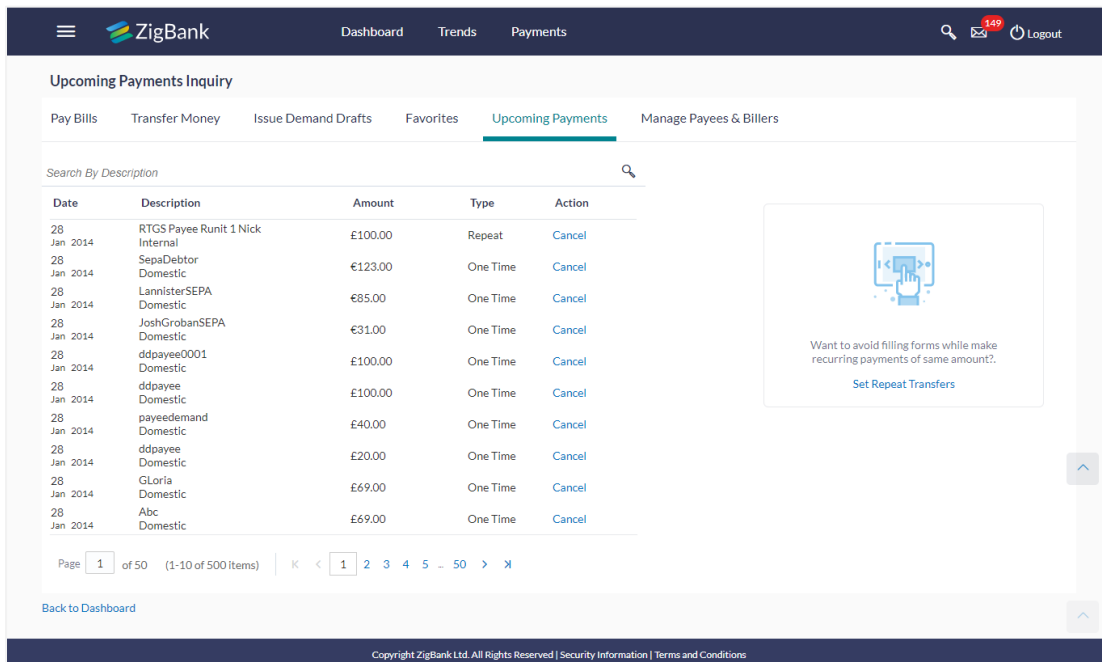

Date	Description	Amount	Type	Action
28 Jan 2014	RTGS Payee Runit 1 Nick Internal	£100.00	Repeat	Cancel
28 Jan 2014	SepaDebtor Domestic	€123.00	One Time	Cancel
28 Jan 2014	LannistarSEPA Domestic	€85.00	One Time	Cancel
28 Jan 2014	JoshGrobanSEPA Domestic	€31.00	One Time	Cancel
28 Jan 2014	ddpayee0001 Domestic	£100.00	One Time	Cancel
28 Jan 2014	ddpayee Domestic	£100.00	One Time	Cancel
28 Jan 2014	payeedemand Domestic	£40.00	One Time	Cancel
28 Jan 2014	ddpayee Domestic	£20.00	One Time	Cancel
28 Jan 2014	GLoria Domestic	£69.00	One Time	Cancel
28 Jan 2014	Abc Domestic	£69.00	One Time	Cancel

### Field Name Description

**Date** The date on which the payment transaction is due for processing.

**Description** The description of the payment transaction. This can include details such as name of the payee as well as the type of transfer.

**Amount** The transfer amount and currency.

**Type** The type of transfer.

The payment type will be mainly categorized as:

- One Time: Scheduled Single Payment
- Repeat: Repeat Transfer

**Field Name Description**

**Action** The option to cancel the transaction.

- 2. To cancel the transaction, click **Cancel**. The 'Cancel Transfer' pop-up with a message prompting the user to cancel the transfer appears.

### 18.2 Upcoming Payments – View & Cancel

On selecting the option to cancel the transaction, a pop up window appears containing the details of the transaction. The user can view these details and confirm cancellation.

**To cancel the transaction:**

- 1. Click **Cancel** against the record that you want to delete. The 'Cancel Transfer' pop-up appears which displays basic details of the transaction and also contains a button by which the user can confirm cancellation.

#### Upcoming Payments - Cancel Transfer

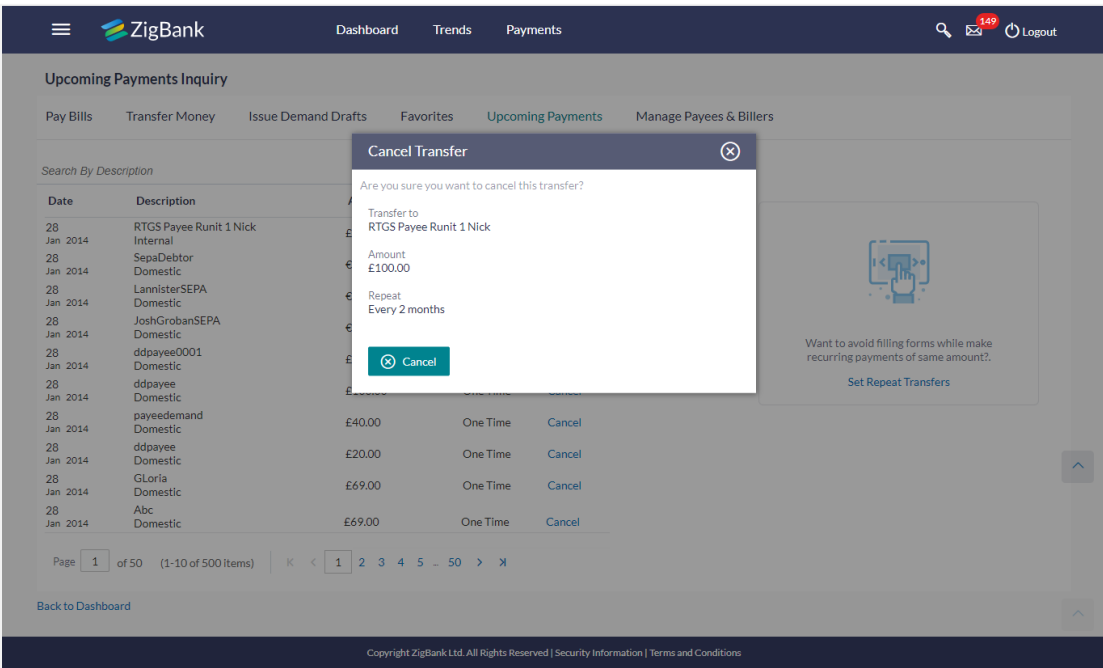

2. Click **Cancel** to confirm the cancellation. The **Verification** screen appears if the transaction is configured for Two Factor Authentication.
3. A message confirming cancellation of the transaction along with host reference number and transaction details appear.  
Click **Go to Dashboard** to navigate to the dashboard.  
OR  
Click **More Payment Options** to access other payment options

## **FAQ**

### **1. What are the types of payments that are shown under "Upcoming Payments"?**

The following type of payments will be shown under the 'Upcoming Payments' based on transaction processing date:

- Future Dated Transfers
- Future Dated Demand Drafts
- Upcoming Repeat Transfers

### **2. Can I cancel the upcoming payment which is due today?**

Cancellation of today's upcoming payment depends upon the bank's processing cycle of upcoming payments. If the bank processes all upcoming payments during same day's BOD process, then you will not be allowed to cancel payments due today.

### **3. Can I cancel a specific installment of a repeat transfer/recurring payment?**

No, you cannot cancel the specific installment of recurrent payment, but you can cancel entire instruction given for recurring payment.

### **4. Can I cancel an upcoming payment that has been initiated from any channel other than the online banking channel?**

Yes, you can cancel any upcoming transaction initiated by you through any channel.

[Home](#)

## 19. Common Functions

The common procedure to be followed for below option:

### Add Favorite

Save the transaction as favorite for frequently used transactions.

### Set Repeat Transfer

Enables the user to set a standing instruction.





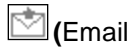

Allows the user to save the transaction log in .pdf format.



Allows the user to mail the transaction search result using default mail configured.

### To sort the Records

1. From the Page list, select the required page number of the transactions list.
2. Click  to sort records in ascending or descending order.
3. Click to  view the first page of the transaction record list.  
OR  
Click to  view the previous page of the transaction record list.  
OR  
Click to  view the next page of the transaction record list.  
OR  
Click to  view the last page of the transaction record list.

[Home](#)